

# CITY OF MERCER ISLAND

## DEVELOPMENT SERVICES GROUP

9611 SE 36TH STREET | MERCER ISLAND, WA 98040

PHONE: 206.275.7605 | [www.mercergov.org](http://www.mercergov.org)

Inspection Requests: Online: [www.MyBuildingPermits.com](http://www.MyBuildingPermits.com) VM: 206.275.7730



## SECTION A: SMALL PROJECT STORMWATER SITE PLAN/REPORT

### Narrative and Plan Submittal

**Instructions:** This is a template for a simplified Stormwater Report. This form or an equivalent must accompany your Building Permit Application if the answer is "Yes" to each statement below. If "No" is the answer to one or more of the statements below, a full Drainage Report is required and the project does not qualify for use of the Small Project Stormwater Site Plan/Report template.

Select "yes" or "no" for each statement below. Answer "yes" if the statement accurately describes your project.

Yes	No	Statement
✓		This project disturbs less than 1 acre and is not part of a larger common plan of development.
✓		This project converts less than 3/4 acre to lawn or landscape areas.
✓		This project will create, add, or replace (in any combination) 2,000 square feet or greater, but less than 5,000 square feet, of new plus replaced hard surface <b>OR</b> will have a land disturbing activity of 7,000 square feet or greater <b>OR</b> will result in a net increase of impervious surface of 500 square feet or greater.
✓		This project will not adversely impact a wetland, stream, water of the state, or change a natural drainage course.

### Basic Project Information

Project Name: Knotz Remodel

Site Address: 6020 94th Avenue SE

Total Lot Size: 14,444 sf

Total Proposed Area to be Disturbed (including stockpile area): 4,150 sq ft

Total Volume of Proposed Cut and Fill: 40 sq ft

Total Proposed New Hard Surface Area: 1,488 sq ft

Total Proposed Replaced Hard Surface Area: 702 sq ft

Total Proposed Converted Pervious Surface Area 0  
(Native vegetation to lawn or landscape): \_\_\_\_\_ sq ft

Net Increase in Impervious Surface: 1,488 sq ft



# CITY OF MERCER ISLAND

## SECTION A: SMALL PROJECT STORMWATER SITE PLAN/REPORT

### Minimum Requirement #1 : Preparation of Stormwater Site Plan

#### Written Project Description:

The project is a remodel of an existing single-family residence. The west wall and a portion of the north wall of the house will be removed and the building expanded to create more living space. An existing deck will be removed and replaced, and a patio added behind the garage. The existing living space will remain with some internal remodeling. The garage and driveway will remain as is.

Stormwater from the new and replaced roof, and the new patio will be collected and routed to a proposed detention tank located near the southeast corner of the garage. The proposed deck will be drip-through onto compost amended soils. The area of the proposed deck is excluded from the detention calculation.

#### Calculate new or replaced areas by surface type:

Lawn or Landscape Areas: <u>0</u> sq ft	Roof Area: <u>1,075</u> sq ft	
Other Hard Surface Areas:		
Driveway: <u>0</u> sq ft	Patio: <u>406</u> sq ft	Sidewalk: <u>0</u> sq ft
Parking Lot: <u>0</u> sq ft	Other: <u>709 (deck)</u> sq ft	

Attach Drainage Plan

#### Drainage Plan shall include the following:

- Scaled drawing with slopes, lot lines, any public-right-of-way and any easements, location of each on-site stormwater management BMP selected above and the areas served by them, buildings, roads, parking lots, driveways, landscape features, and areas of disturbed soils to be amended.
- The scaled drawing must be suitable to serve as a recordable document that will be attached to the property deed for each lot that includes on-site BMPs. Document submittal must follow the "Standard Formatting Requirements for Recording Documents" per King County: [www.kingcounty.gov/depts/records-licensing/records-office/recording-documents.aspx](http://www.kingcounty.gov/depts/records-licensing/records-office/recording-documents.aspx)
- Identify design details and maintenance instructions for each on-site BMP, and attach them to this Small Project Stormwater Site Plan/Report.



# CITY OF MERCER ISLAND

## SECTION A: SMALL PROJECT STORMWATER SITE PLAN/REPORT

### Minimum Requirement #2 : Construction Stormwater Pollution Prevention

- Complete Section B of this submittal package: Construction Stormwater Pollution Prevention Plan Narrative (SWPPP)
- Attach construction SWPPP

### Minimum Requirement #3 : Source Control of Pollution

This section contains practices and procedures to reduce the release of pollutants. Provide a description of all known, available and reasonable source control BMPs that will be, or are anticipated to be, used at this location to prevent stormwater from coming into contact with pollutants. Additional BMPs are found in Volume IV of the 2014 Stormwater Management Manual for Western Washington (SWMMWW).

Check the BMPs you will use:

- BMP S411 for Landscaping and Lawn/ Vegetation Management  
Operational practices for sites with landscaping
- BMP S421 for Parking and Storage of Vehicles.  
Public and commercial parking lots can be sources of suspended solids, metals, or toxic hydrocarbons such oils and greases.
- BMP S433 for Pools, Spas, Hot Tubs, Fountains  
Discharge from pools, hot tubs, and fountains can degrade ambient water quality. Routine maintenance activities generate a variety of wastes. Direct disposal of these waters to drainage system and waters of the state are not permitted without prior treatment and approval.
- Other BMPs found in Volume IV of SWMMWW applicable to project:

- No source control BMPs are applicable for this project.



# CITY OF MERCER ISLAND

## SECTION A: SMALL PROJECT STORMWATER SITE PLAN/REPORT

### Minimum Requirement #4 : Preservation of Natural Drainage Systems

Natural drainage patterns shall be maintained and discharges from the project site shall occur at the natural location, to the maximum extent practicable. All outfalls require energy dissipation.

Choose the option below that best describes your project:

This site has existing drainage systems or outfalls. These items are shown on the Drainage Plan. Include the following items on the Drainage Plan:

- Pipe invert elevations, slopes, cover, and material
- Locations, grades, and direction of flow in ditches and swales, culverts, and pipes

Describe how these systems will be preserved:

This site does not have any existing drainage systems or outfalls.

Additional Comments:

The existing drainage direction is south into the right-of-way. Site runoff that flows into the right-of-way is collected by a catchbasin in the pavement flow line and directed to the City storm drainage system. The proposed drainage connection is to the same City drainage system.



# CITY OF MERCER ISLAND

## SECTION A: SMALL PROJECT STORMWATER SITE PLAN/REPORT

### Minimum Requirement #5 : On-site Stormwater Management

All projects meeting the thresholds for this Small Project Stormwater Report shall employ on-site stormwater management BMPs (See Small Project Stormwater Requirements Tip Sheet) to infiltrate, disperse, and retain stormwater runoff on-site to the extent feasible without causing flooding or erosion impacts.

#### List #1

For each category select the *first* feasible item on the list below. Document your justification for each infeasible BMP in Section C of this submittal package.

Check one option for each category below:



#### Lawn and Landscape Areas

- My project does not have *Lawn or Landscape* areas
- Post-construction soil quality and depth
- Post-construction soil quality and depth is infeasible (see Section C of this submittal package)



#### Roofs

- My project does not have *Roof* areas
- 1. Full dispersion or downspout full infiltration
- 2. Rain garden or bioretention
- 3. Downspout dispersion system
- 4. Perforated stub-out connections
- 5. On-site detention system or fee-in-lieu of on-site detention authorized by the City Engineer (applicable if options #1-4 are infeasible and drainage from the site will be discharged to a storm or surface water system that includes a watercourse or there is a capacity constraint in the system)
- 6. No Roof BMP (applicable if options #1-4 are infeasible and on-site detention is not required)

Measured Infiltration Rate: \_\_\_\_\_ in/ hr

If #5 or #6 is selected, briefly describe why no Roof BMP is feasible (include detailed information in Section C of this submittal package):

The site is not large enough to accommodate the full dispersion flowpath.

Evaluation of infiltration is not required per the Infiltration Infeasibility Map eliminating full infiltration, rain gardens, bioretention, and perforated stub-outs.

There is insufficient flow path length to impervious areas or slopes over 15% for downspout dispersion.



# CITY OF MERCER ISLAND

## SECTION A: SMALL PROJECT STORMWATER SITE PLAN/REPORT

### Minimum Requirement #5 : On-site Stormwater Management (cont.)



#### Other Hard Surfaces (such as driveway, sidewalk, parking lot, patio, etc.)

- My project does not have *Other Hard Surface* areas
- 1. Full dispersion
- 2. Permeable pavement, rain gardens, or bioretention
- 3. Sheet flow dispersion or concentrated flow dispersion
- 4. On-site detention system or fee-in-lieu of on-site detention authorized by the City Engineer (applicable if options #1-3 are infeasible and drainage from the site will be discharged to a storm or surface water system that includes a watercourse or there is a capacity constraint in the system)
- 5. No Other Hard Surface BMP (applicable if options #1-3 are infeasible and on-site detention is not required)

Measured Infiltration Rate: \_\_\_\_\_ in/ hr

If #4 or #5 is selected, briefly describe why no Other Hard Surface BMP is feasible (include detailed information in Section C of this submittal package):

The site is not large enough to accommodate the full dispersion flowpath.

Evaluation of infiltration is not required per the Infiltration Infeasibility Map eliminating rain gardens, bioretention and permeable pavement.

The dispersal area for the patio is over 20% making sheet flow and concentrated dispersion infeasible.

### Flow Control Exempt List

Proceed with this list if your project discharges directly to Lake Washington or if findings from a downstream analysis confirm that the downstream system is free of capacity constraints for a minimum of ¼ mile and a maximum of 1 mile.

For flow control exempt discharges, the BMPs listed below for Roofs and Other Hard Surfaces do not need to be evaluated in priority order. You can select any BMP from the lists provided below and do not need to document infeasibility in Section C of this submittal package.

Check one option for each category below:



#### Lawn and Landscape Areas

- My project does not have *Lawn or Landscape* areas
- Post-construction soil quality and depth



# CITY OF MERCER ISLAND

## SECTION A: SMALL PROJECT STORMWATER SITE PLAN/REPORT

### Minimum Requirement #5 : On-site Stormwater Management (cont.)



#### Roofs

- My project does not have *Roof* areas
- Downspout full infiltration
- Downspout dispersion system
- Perforated stub-out connections
- Each item above is infeasible

If “Each item above is infeasible” is selected, briefly describe why no Roof BMP is feasible:



#### Other Hard Surfaces (such as driveway, sidewalk, parking lot, patio, etc.)

- My project does not have *Other Hard Surface* areas
- Sheet flow dispersion
- Concentrated flow dispersion
- Each item above is infeasible

If “Each item above is infeasible” is selected, briefly describe why no Other Hard Surface BMP is feasible:



# CITY OF MERCER ISLAND

## SECTION B: SMALL PROJECT CONSTRUCTION SWPPP NARRATIVE

### Instructions

This is a template for a simplified Construction Stormwater Pollution Prevention Plan (“Construction SWPPP”). If “No” is the answer to one or more of the statements on the first page of Section A of this submittal package, then a full Construction SWPPP is required and the project does not qualify for the use of the Small Project Construction SWPPP Narrative template. If the project is less than the thresholds on the first page of Section A of this submittal package, then Minimum Requirement #2 still applies, but this section (Section B) or a full construction SWPPP is not required. You should include your Construction SWPPP in your contract with your builder. A copy of the Construction SWPPP must be located at the construction site or within reasonable access to the site for construction and inspection personnel at all times.

### General Information on the Existing Site and Project

Describe the following in the Project Narrative box below (attach additional pages if necessary):

- Nature and purpose of the construction project
- Existing topography, vegetation, and drainage, and building structures
- Adjacent areas, including streams, lakes, wetlands, residential areas, and roads that might be affected by the construction project
- How upstream drainage areas may affect the site
- Downstream drainage leading from the site to the receiving body of water
- Areas on or adjacent to the site that are classified as critical areas
- Critical areas that receive runoff from the site up to one-quarter mile away
- Special requirements and provisions for working near or within critical areas
- Areas on the site that have potential erosion problems

Project Narrative:

The project is a remodel of a single-family residence that includes building additions, a replaced deck, and a new patio.

Existing drainage from the property is surface flow to the south. There is no obvious constructed drainage system. Runoff from the existing driveway flows directly into the street. Roof downspouts connect to below-grade pipes that may connect to the City system or to drywells.

Roof runoff will be collected by gutters and downspouts. Runoff from the patio will be collected by a French drain. Deck runoff will drip through to amended soils beneath. Collected runoff from the new improvements will be mitigated in a 48" diameter detention pipe then carried by a 6-inch diameter pipe to connect to the City drainage system in the right-of-way.

The existing terrain slope is moderate and averages about 17% over the property. The slope increases to over 40% at the east property line. Existing vegetation consists of lawn and shrubs.

Offsite drainage enters the property from up-slope properties to the west and north. The runoff is from landscaped portions of adjacent single-family residential properties and is probably not significant in volume.

Disturbance and exposure of soils during construction has a potential for erosion. Given the modest development scope the potential for erosion can be effectively mitigated by construction BMPs and phasing.





# CITY OF MERCER ISLAND

## SECTION B: SMALL PROJECT CONSTRUCTION SWPPP NARRATIVE

### Construction SWPPP Drawings

Refer to the general Drawing Requirements in Stormwater Management Manual for Western Washington (SWMMWW) Volume I, Chapter 3.

### Vicinity Map

Provide a map with enough detail to identify the location of the construction site, adjacent roads, and receiving waters.

### Site Map

Include the following (where applicable):

- |   |   |
|---|---|
| <input checked="" type="checkbox"/> Legal description of the property boundaries or an illustration of property lines (including distances) on the drawings.          | <input type="checkbox"/> Final and interim grade contours as appropriate, drainage basins, and the direction of stormwater flow during and upon completion of construction. |
| <input checked="" type="checkbox"/> North arrow.  | <input checked="" type="checkbox"/> Areas of soil disturbance, including all areas affected by clearing, grading, and excavation.   |
| <input checked="" type="checkbox"/> Existing structures and roads.  | <input type="checkbox"/> Locations where stormwater will discharge to surface waters during and upon completion of construction.  |
| <input type="checkbox"/> Boundaries and identification of different soil types.   | <input type="checkbox"/> Existing unique or valuable vegetation and vegetation to be preserved.   |
| <input type="checkbox"/> Areas of potential erosion problems.   | <input type="checkbox"/> Cut-and-fill slopes indicating top and bottom of slope catch lines.  |
| <input type="checkbox"/> Any on-site and adjacent surface waters, critical areas, buffers, flood plain boundaries, and Shoreline Management boundaries.               | <input type="checkbox"/> Total cut-and-fill quantities and the method of disposal for excess material.  |
| <input checked="" type="checkbox"/> Existing contours and drainage basins and the direction of flow for the different drainage areas.                                 | <input checked="" type="checkbox"/> Stockpile; waste storage; and vehicle storage, maintenance, and washdown areas.   |
| <input checked="" type="checkbox"/> Where feasible, contours extend a minimum of 25 feet beyond property lines and extend sufficiently to depict existing conditions. |   |

### Temporary and Permanent BMPs

Include the following on site map (where applicable):

- |   |   |
|---|---|
| <input type="checkbox"/> Locations for temporary and permanent swales, interceptor trenches, or ditches.                                      | <input type="checkbox"/> Details for bypassing off-site runoff around disturbed areas.  |
| <input type="checkbox"/> Drainage pipes, ditches, or cut-off trenches associated with erosion and sediment control and stormwater management. | <input type="checkbox"/> Locations of temporary and permanent stormwater treatment and/or flow control best management practices (BMPs).  |
| <input type="checkbox"/> Temporary and permanent pipe inverts and minimum slopes and cover.   | <input checked="" type="checkbox"/> Details for all structural and nonstructural erosion and sediment control (ESC) BMPs (including, but not limited to, silt fences, construction entrances, sedimentation facilities, etc.) |
| <input type="checkbox"/> Grades, dimensions, and direction of flow in all ditches and swales, culverts, and pipes.                            | <input type="checkbox"/> Details for any construction-phase BMPs or techniques used for Low Impact Development (LID) BMP protection.  |
| <input type="checkbox"/> Locations and outlets of any dewatering systems.   |   |



# CITY OF MERCER ISLAND

## SECTION B: SMALL PROJECT CONSTRUCTION SWPPP NARRATIVE

### Element 1: Preserve Vegetation / Mark Clearing Limits

The goal of this element is to preserve native vegetation and to clearly show the limits of disturbance.

This element **does not** apply to my project because:

The site was cleared as part of clearing activity that is subject to an enforcement action and is re-vegetated. Restoration may be necessary to comply with Critical Area Regulations or NPDES requirements. Buffer Zones-BMP C102 may apply if Critical Areas exist on-site and buffer zones shall be protected.

Other Reason / Additional Comments:

If it **does** apply, describe the steps you will take and select the best management practices (BMPs) you will use:

The perimeter of the area to be cleared shall be marked prior to clearing operation with visible flagging, orange plastic barrier fencing and/or orange silt fencing as shown on the SWPPP site map. The total disturbed area shall be less than 7,000 square feet. Vehicles will only be allowed in the areas to be graded, so no compaction of the undeveloped areas will occur.

Additional Comments:

Limits of disturbance will be delineated with orange barrier fence and silt fence.

Check the BMPs you will use:

- C101 Preserving Natural Vegetation       C102 Buffer Zones       C103 High Visibility Fence



# CITY OF MERCER ISLAND

## SECTION B: SMALL PROJECT CONSTRUCTION SWPPP NARRATIVE

### Element 2: Construction Access

The goal of this element is to provide a stabilized construction entrance/exit to prevent or reduce or sediment track out.

This element **does not** apply to my project because:

The driveway to the construction area already exists and will be used for construction access. All equipment and vehicles will be restricted to staying on that existing impervious surface.

Other Reason / Additional Comments:

If it **does** apply, describe the steps you will take and select the BMPs you will use:

A stabilized construction entrance will be installed prior to any vehicles entering the site, at the location shown on the SWPPP site map.

Additional Comments:

Check the BMPs you will use:

C105 Stabilized Construction Entrance / Exit

C106 Wheel Wash

C107 Construction Road / Parking Area Stabilization



# CITY OF MERCER ISLAND

## SECTION B: SMALL PROJECT CONSTRUCTION SWPPP NARRATIVE

### Element 3: Control Flow Rates

The goal of this element is to construct retention or detention facilities when necessary to protect properties and waterways downstream of development sites from erosion and turbid discharges.

This element **does not** apply to my project because:

Other Reason / Additional Comments:

The disturbed area is too small to warrant a flow control facility.

If it **does** apply, describe the steps you will take and select the BMPs you will use:

Flow rates will be controlled by using SWPPP Element 4 sediment controls and BMP T5.13 Post-Construction Soil Quality and Depth if necessary.

Additional Comments:



# CITY OF MERCER ISLAND

## SECTION B: SMALL PROJECT CONSTRUCTION SWPPP NARRATIVE

### Element 4: Sediment Control

The goal of this element is to construct sediment control BMPs that minimize sediment discharges from the site.

This element **does not** apply to my project because:

The site has already been stabilized and re-vegetated.

Other Reason / Additional Comments:

If it **does** apply, describe the steps you will take and select the BMPs you will use:

Sediment control BMPs shall be placed at the locations shown on the SWPPP site map

Additional Comments:

Sediment control facilities will consist of silt fence at the downslope perimeter.

Check the BMPs you will use:

C231 Brush Barrier

C233 Silt Fence

C235 Wattles

C232 Gravel Filter Berm

C234 Vegetated Strip



# CITY OF MERCER ISLAND

## SECTION B: SMALL PROJECT CONSTRUCTION SWPPP NARRATIVE

### Element 5: Stabilize Soils

The goal of this element is to stabilize exposed and unworked soils by implementing erosion control BMPs.

This element **does not** apply to my project because:

Other Reason / Additional Comments:

If it **does** apply, describe the steps you will take and select the BMPs you will use:

- Exposed soils shall be worked during the week until they have been stabilized. Soil stockpiles will be located within the disturbed area shown on the SWPPP site map. Soil excavated for the foundation will be backfilled against the foundation and graded to drain away from the building. No soils shall remain exposed and unworked for more than 7 days from May 1 to September 30 or more than 2 days from October 1 to April 30. Once the disturbed landscape areas are graded, the grass areas will be amended using BMP T5.13 Post-Construction Soil Quality and Depth. All stockpiles will be covered with plastic or burlap if left unworked.

Additional Comments:

Mulch disturbed soils that will not be immediately covered by permanent improvements or landscaping.

Check the BMPs you will use:

- C120 Temporary & Permanent Seeding
- C122 Nets & Blankets
- C124 Sodding
- C131 Gradient Terraces
- C235 Wattles
- C121 Mulching
- C123 Plastic Covering
- C125 Topsoil / Composting
- C140 Dust Control



# CITY OF MERCER ISLAND

## SECTION B: SMALL PROJECT CONSTRUCTION SWPPP NARRATIVE

### Element 6: Protect Slopes

The goal of this element is to design and construct cut-and-fill slopes in a manner to minimize erosion.

This element **does not** apply to my project because:

No cut slopes over 4 feet high or slopes steeper than 2 feet horizontal to 1 foot vertical, and no fill slopes over 4 feet high will exceed 3 feet horizontal to 1 foot vertical. Therefore, there is no requirement for additional engineered slope protection.

Other Reason / Additional Comments:

If it **does** apply, describe the steps you will take and select the BMPs you will use:

Additional Comments:

Check the BMPs you will use:

- |   |   |   |
|---|---|---|
| <input type="checkbox"/> C120 Temporary & Permanent Seeding | <input type="checkbox"/> C205 Subsurface Drains | <input type="checkbox"/> C207 Check Dams  |
| <input type="checkbox"/> C204 Pipe Slope Drains             | <input type="checkbox"/> C206 Level Spreader    | <input type="checkbox"/> C208 Triangular Silt Dike (Geotextile-Encased Check Dam) |



# CITY OF MERCER ISLAND

## SECTION B: SMALL PROJECT CONSTRUCTION SWPPP NARRATIVE

### Element 7: Protect Permanent Drain Inlets

The goal of this element is to protect storm drain inlets during construction to prevent stormwater runoff from entering the conveyance system without being filtered or treated.

This element **does not** apply to my project because:

- The site has open ditches in the right-of-way or private road right-of-way.
- There are no catch basins on or near the site.
- Other Reason / Additional Comments:

If it **does** apply, describe the steps you will take and select the BMPs you will use:

- Catch basins on the site or immediately off site in the right-of-way are shown on the SWPPP site map. Storm drain inlet protection shall be installed.

Additional Comments:

Check the BMPs you will use:

- C220 Storm Drain Inlet Protection





# CITY OF MERCER ISLAND

## SECTION B: SMALL PROJECT CONSTRUCTION SWPPP NARRATIVE

### Element 8: Stabilize Channels and Outlets

The goal of this element is to design, construct, and stabilize on-site conveyance channels to prevent erosion from entering existing stormwater outfalls and conveyance systems.

This element **does not** apply to my project because:

Construction will occur during the dry weather. No storm drainage channels or ditches shall be constructed either temporary or permanent. A small swale shall be graded to convey yard drainage around the structure using a shallow slope; it shall be seeded after grading and stabilized.

Other Reason / Additional Comments:

If it **does** apply, describe the steps you will take and select the BMPs you will use:

A wattle shall be placed at the end of the swale to prevent erosion at the outlet of the swale.

Additional Comments:

Check the BMPs you will use:

C202 Channel Lining     C207 Check Dams     C209 Outlet Protection     C235 Wattles



# CITY OF MERCER ISLAND

## SECTION B: SMALL PROJECT CONSTRUCTION SWPPP NARRATIVE

### Element 9: Control Pollutants

The goal of this element is to design, install, implement and maintain BMPs to minimize the discharge of pollutants from material storage areas, fuel handling, equipment cleaning, management of waste materials, etc.

This element **does not** apply to my project because:

Other Reason / Additional Comments:

If it **does** apply, describe the steps you will take and select the BMPs you will use:

- Any and all pollutants, chemicals, liquid products and other materials that have the potential to pose a threat to human health or the environment will be covered, contained, and protected from vandalism. All such products shall be kept under cover in a secure location on-site. Concrete handling shall follow BMP C151.

Additional Comments:

See also pollution control notes on the plans.

Check the BMPs you will use:

- |  |  |
|--|--|
| <input checked="" type="checkbox"/> C151 Concrete Handling                           | <input checked="" type="checkbox"/> C152 Sawcutting and Surfacing Pollution Prevention |
| <input checked="" type="checkbox"/> C153 Material Delivery, Storage, and Containment | <input checked="" type="checkbox"/> C154 Concrete Washout Area                         |



# CITY OF MERCER ISLAND

## SECTION B: SMALL PROJECT CONSTRUCTION SWPPP NARRATIVE

### Element 10: Control De-watering

The goal of this element is to handle turbid or contaminated dewatering water separately from stormwater.

This element **does not** apply to my project because:

No dewatering of the site is anticipated.

Other Reason / Additional Comments:

There is no deep excavation planned for the development.

If it **does** apply, describe the steps you will take and select the BMPs you will use:

Additional Comments:

Check the BMPs you will use:

C203 Water Bars

C236 Vegetated Filtration

C206 Level Spreader



# CITY OF MERCER ISLAND

## SECTION B: SMALL PROJECT CONSTRUCTION SWPPP NARRATIVE

### Element 11: Maintain Best Management Practices

The goal of this element is to maintain and repair all temporary and permanent erosion and sediment control BMPs to assure continued performance.

*Describe the steps you will take:*

- Best Management Practices or BMPs shall be inspected and maintained during construction and removed within 30 days after the City Inspector or Engineer determines that the site is stabilized, provided that they may be removed when they are no longer needed.

### Element 12: Manage the Project

The goal of this element is to ensure that the construction SWPPP is properly coordinated and that all BMPs are deployed at the proper time to achieve full compliance with City regulations throughout the project.

If it **does** apply, describe the steps you will take and select the BMPs you will use:

The Construction SWPPP will be implemented at all times. The applicable erosion control BMPs will be implemented in the following sequence:

- 1. Mark clearing limits
- 2. Install stabilized construction entrance
- 3. Install protection for existing drainage systems and permanent drain inlets
- 4. Establish staging areas for storage and handling polluted material and BMPs
- 5. Install sediment control BMPs
- 6. Grade and install stabilization measures for disturbed areas
- 7. Maintain BMPs until site stabilization, at which time they may be removed

Additional Comments:



# CITY OF MERCER ISLAND

## SECTION B: SMALL PROJECT CONSTRUCTION SWPPP NARRATIVE

### Element 13: Protect Low Impact Development BMPs

The goal of this element is to protect on-site stormwater management BMPs (also known as “Low Impact Development BMPs”) from siltation and compaction during construction. On-site stormwater management BMPs used for runoff from roofs and other hard surfaces include: full dispersion, roof downspout full infiltration or dispersion systems, perforated stubout connections, rain gardens, bioretention systems, permeable pavement, sheetflow dispersion, and concentrated flow dispersion. Methods for protecting on-site stormwater management BMPs include sequencing the construction to install these BMPs at the latter part of the construction grading operations, excluding equipment from the BMPs and the associated areas, and using the erosion and sedimentation control BMPs listed below.

*Describe the construction sequencing you will use:*

Additional Comments:

There are no BMPs proposed for the development.

*Select the BMPs you will use:*

- |   |   |   |
|---|---|---|
| <input type="checkbox"/> C102 Buffer Zone | <input type="checkbox"/> C103 High Visibility Fence | <input type="checkbox"/> C231 Brush Barrier |
| <input type="checkbox"/> C233 Silt Fence  | <input type="checkbox"/> C234 Vegetated Strip       |   |



# CITY OF MERCER ISLAND

## SECTION C: INFEASIBILITY CRITERIA

### Minimum Requirement #5 (On-Site Stormwater Management)

The following tables summarize infeasibility criteria that can be used to justify not using various on-site stormwater management best management practices (BMPs) for consideration for Minimum Requirement #5. This information is also included under the detailed descriptions of each BMP in the 2014 Stormwater Management Manual for Western Washington (Stormwater Manual), but is provided here in this worksheet for additional clarity and efficiency. Where any inconsistencies or lack of clarity exists, the requirements in the main text of the Stormwater Manual shall be applied. If a project is limited by one or more of the infeasibility criteria specified below, but an applicant is interested in implementing a specific BMP, a functionally equivalent design may be submitted to the City for review and approval. Evaluate the feasibility of the BMPs in priority order based on List #1 or #2 (Small Project Stormwater Requirements Tip Sheet and Stormwater Manual). Select the first BMP that is considered feasible for each surface type. Document the infeasibility (narrative description and rationale) for each BMP that was not selected. Only one infeasibility criterion needs to be selected for a BMP before evaluating the next BMP on the list. Attach additional pages for supporting information if necessary.

Note: If your project discharges directly to Lake Washington (flow control exempt) or a downstream analysis confirms that the downstream system is free of capacity constraints for a minimum of ¼ mile and a maximum of 1 mile, then you do not need to complete this worksheet, but should still refer to the infeasibility criteria when selecting BMPs.

Lawn and Landscaped Areas		
BMP and Applicable Lists	Infeasibility Criteria	Infeasibility Description and Rationale for Each BMP Not Selected
Post-construction Soil Quality and Depth List #1 and #2	<input type="checkbox"/> Siting and design criteria provided in BMP T5.13 ( <b>Stormwater Manual</b> Volume V, Section 5.3) cannot be achieved.  <input type="checkbox"/> Lawn and landscape area is on till slopes greater than 33 percent.	
Roofs		
BMP and Applicable Lists	Infeasibility Criteria	Infeasibility Description and Rationale for Each BMP Not Selected
Full Dispersion List #1 and #2	<input type="checkbox"/> Site setbacks and design criteria provided in BMP T5.30 ( <b>Stormwater Manual</b> Volume V, Section 5.3) cannot be achieved.  <input type="checkbox"/> A 65 to 10 ratio of forested or native vegetation area to impervious area cannot be achieved.  <input checked="" type="checkbox"/> A minimum forested or native vegetation flowpath length of 100 feet (25 feet for sheet flow from a non-native pervious surface) cannot be achieved.	
Downspout Full Infiltration List #1 and #2	<input checked="" type="checkbox"/> Evaluation of infiltration is not required per the Infiltration Infeasibility Map due to steep slopes, erosion hazards, or landslide hazards.  <input type="checkbox"/> Site setbacks and design criteria provided in BMP T5.10A ( <b>Stormwater Manual</b> Volume III, Section 3.1.1) cannot be achieved.  <input type="checkbox"/> The lot(s) or site does not have out-wash or loam soils.  <input type="checkbox"/> There is not at least 3 feet or more of permeable soil from the proposed final grade to the seasonal high groundwater table or other impermeable layer.  <input type="checkbox"/> There is not at least 1 foot or more of permeable soil from the proposed bottom of the infiltration system to the seasonal high groundwater table or other impermeable layer.	



# CITY OF MERCER ISLAND

## SECTION C: INFEASIBILITY CRITERIA

Roofs (cont.)		
BMP and Applicable Lists	Infeasibility Criteria	Infeasibility Description and Rationale for Each BMP Not Selected
Bioretention or Rain Gardens  List #1 (both) and List #2 (bioretention only)	<p><i>Note: Criteria with setback distances are as measured from the bottom edge of the bioretention soil mix.</i></p> <p>Citation of any of the following infeasibility criteria must be based on an evaluation of site-specific conditions and a written recommendation from an appropriate licensed professional (e.g., engineer, geologist, hydrogeologist):</p> <ul style="list-style-type: none"> <li><input type="checkbox"/> Where professional geotechnical evaluation recommends infiltration not be used due to reasonable concerns about erosion, slope failure, or down-gradient flooding.</li> <li><input type="checkbox"/> Within an area whose ground water drains into an erosion hazard, or landslide hazard area.</li> <li><input type="checkbox"/> Where the only area available for siting would threaten the safety or reliability of pre-existing underground utilities, pre-existing underground storage tanks, pre-existing structures, or pre-existing road or parking lot surfaces.</li> <li><input type="checkbox"/> Where the only area available for siting does not allow for a safe overflow pathway to stormwater drainage system or private storm sewer system.</li> <li><input type="checkbox"/> Where there is a lack of usable space for bioretention areas at re-development sites, or where there is insufficient space within the existing public right-of-way on public road projects.</li> <li><input type="checkbox"/> Where infiltrating water would threaten existing below grade basements.</li> <li><input type="checkbox"/> Where infiltrating water would threaten shoreline structures such as bulkheads.</li> </ul> <p>The following criteria can be cited as reasons for infeasibility without further justification (though some require professional services to make the observation):</p> <ul style="list-style-type: none"> <li><input checked="" type="checkbox"/> Evaluation of infiltration is not required per the Infiltration Infeasibility Map due to steep slopes, erosion hazards, or landslide hazards</li> <li><input type="checkbox"/> Within setback provided for BMP T7.30 (<b>Stormwater Manual</b> Volume V, Section 7.4)</li> <li><input type="checkbox"/> Where they are not compatible with surrounding drainage system as determined by the city (e.g., project drains to an existing stormwater collection system whose elevation or location precludes connection to a properly functioning bioretention area).</li> </ul>	



# CITY OF MERCER ISLAND

## SECTION C: INFEASIBILITY CRITERIA

Roofs (cont.)		
BMP and Applicable Lists	Infeasibility Criteria	Infeasibility Description and Rationale for Each BMP Not Selected
Bioretention or Rain Gardens (cont.)	<p>The following criteria can be cited as reasons for infeasibility without further justification (though some require professional services to make the observation):</p> <ul style="list-style-type: none"> <li><input type="checkbox"/> Where land for bioretention is within an erosion hazard, or landslide hazard area (as defined by MICC 19.07.060).</li> <li><input type="checkbox"/> Where the site cannot be reasonably designed to locate bioretention areas on slopes less than 8 percent.</li> <li><input type="checkbox"/> Within 50 feet from the top of slopes that are greater than 20 percent and over 10 feet of vertical relief.</li> <li><input type="checkbox"/> For properties with known soil or groundwater contamination (typically federal Superfund sites or state cleanup sites under the Model Toxics Control Act [MTCA]):               <ul style="list-style-type: none"> <li>• Within 100 feet of an area known to have deep soil contamination.</li> <li>• Where groundwater modeling indicates infiltration will likely increase or change the direction of the migration of pollutants in the groundwater.</li> <li>• Wherever surface soils have been found to be contaminated unless those soils are removed within 10 horizontal feet from the infiltration area.</li> <li>• Any area where these facilities are prohibited by an approved cleanup plan under the state MTCA or Federal Superfund Law, or an environmental covenant under Chapter 64.70 RCW.</li> </ul> </li> <li><input type="checkbox"/> Within 100 feet of a closed or active landfill.</li> <li><input type="checkbox"/> Within 10 feet of an underground storage tank and connecting underground pipes when the capacity of the tank and pipe system is 1,100 gallons or less. As used in these criteria, an underground storage tank means any tank used to store petroleum products, chemicals, or liquid hazardous wastes of which 10 percent or more of the storage volume (including volume in the connecting piping system) is beneath the ground surface.</li> <li><input type="checkbox"/> Within 100 feet of an underground storage tank and connecting underground pipes when the capacity of the tank and pipe system is greater than 1,100 gallons.</li> </ul>	





# CITY OF MERCER ISLAND

## SECTION C: INFEASIBILITY CRITERIA

Roofs (cont.)		
BMP and Applicable Lists	Infeasibility Criteria	Infeasibility Description and Rationale for Each BMP Not Selected
Bioretention or Rain Gardens (cont.)	<p>The following criteria can be cited as reasons for infeasibility without further justification (though some require professional services to make the observation):</p> <ul style="list-style-type: none"> <li><input type="checkbox"/> Where field testing indicates potential bioretention/rain garden sites have a measured (a.k.a., initial) native soil saturated hydraulic conductivity less than 0.30 inches per hour. A small-scale or large-scale PIT in accordance with <b>Stormwater Manual</b> Volume III, Section 3.3.6 (or an alternative small scale test specified by the City) shall be used to demonstrate infeasibility of bioretention areas. If the measured native soil infiltration rate is less than 0.30 in/hour, bioretention/rain garden BMPs are not required to be evaluated as an option in List #1 or List #2. In these slow draining soils, a bioretention area with an underdrain may be used to treat pollution-generating surfaces to help meet Minimum Requirement #6, Runoff Treatment. If the underdrain is elevated within a base course of gravel, it will also provide some modest flow reduction benefit that will help achieve Minimum Requirement #7.</li> <li><input type="checkbox"/> Where the minimum vertical separation of 3 feet to the seasonal high groundwater elevation or other impermeable layer would not be achieved below bioretention that would serve a drainage area that exceeds the following thresholds (and cannot reasonably be broken down into amounts smaller than indicated):             <ul style="list-style-type: none"> <li>o 5,000 square feet of pollution-generating impervious surface (PGIS)</li> <li>o 10,000 square feet of impervious area</li> <li>o 0.75 acres of lawn and landscape.</li> </ul> </li> <li><input type="checkbox"/> Where the minimum vertical separation of 1 foot to the seasonal high groundwater or other impermeable layer would not be achieved below bioretention that would serve a drainage area less than the above thresholds.</li> <li><input type="checkbox"/> Within 100 feet of a drinking water well, or a spring used for drinking water supply.</li> <li><input type="checkbox"/> Within 10 feet of small on-site sewage disposal drainfield, including reserve areas, and grey water reuse systems. For setbacks from a "large on-site sewage disposal system," see Chapter 246-272B WAC.</li> </ul>	



# CITY OF MERCER ISLAND

## SECTION C: INFEASIBILITY CRITERIA

Roofs (cont.)		
BMP and Applicable Lists	Infeasibility Criteria	Infeasibility Description and Rationale for Each BMP Not Selected
Downspout Dispersion Systems List #1 and #2	<ul style="list-style-type: none"> <li><input type="checkbox"/> Site setbacks and design criteria provided in BMP T5.10B (<b>Stormwater Manual</b> Volume III, Section 3.1.2) cannot be achieved.</li> <li><input type="checkbox"/> For splash blocks, a vegetated flowpath at least 50 feet in length from the downspout to the downstream property line, structure, stream, wetland, slope over 15 percent, or other impervious surface is not feasible.</li> <li><input checked="" type="checkbox"/> For trenches, a vegetated flowpath of at least 25 feet in between the outlet of the trench and any property line, structure, stream, wetland, or impervious surface is not feasible. A vegetated flowpath of at least 50 feet between the outlet of the trench and any slope steeper than 15 percent is not feasible.</li> </ul>	
Perforated Stub-Out Connections List #1 and #2	<ul style="list-style-type: none"> <li><input checked="" type="checkbox"/> Evaluation of infiltration is not required per the Infiltration Infeasibility Map due to steep slopes, erosion hazards, or landslide hazards</li> <li><input type="checkbox"/> For sites with septic systems, the only location available for the perforated portion of the pipe is located up-gradient of the drainfield primary and reserve areas. This requirement can be waived if site topography will clearly prohibit flows from intersecting the drainfield or where site conditions (soil permeability, distance between systems, etc.) indicate that this is unnecessary.</li> <li><input type="checkbox"/> Site setbacks and design criteria provided in BMP T5.10C (<b>Stormwater Manual</b> Volume III, Section 3.1.3) cannot be achieved.</li> <li><input type="checkbox"/> There is not at least 1 foot of permeable soil from the proposed bottom (final grade) of the perforated stub-out connection trench to the highest estimated groundwater table or other impermeable layer.</li> <li><input type="checkbox"/> The only location available for the perforated stub-out connection is under impervious or heavily compacted soils.</li> </ul>	
On-site Detention List #1 and #2	<ul style="list-style-type: none"> <li><input type="checkbox"/> Project discharges directly to Lake Washington.</li> <li><input type="checkbox"/> Findings from a 1/4 mile downstream analysis confirm that the downstream system is free of capacity constraints.</li> <li><input type="checkbox"/> Site setbacks and design criteria provided in the <b>Stormwater Manual</b> (Volume III, Section 3.2.2) cannot be achieved.</li> </ul>	



# CITY OF MERCER ISLAND

## SECTION C: INFEASIBILITY CRITERIA

Other Hard Surfaces		
BMP and Applicable Lists	Infeasibility Criteria	Infeasibility Description and Rationale for Each BMP Not Selected
Full Dispersion List #1 and #2	<ul style="list-style-type: none"> <li><input type="checkbox"/> Site setbacks and design criteria provided in BMP T5.30 (<b>Stormwater Manual</b> Volume V, Section 5.3) cannot be achieved.</li> <li><input type="checkbox"/> A 65 to 10 ratio of forested or native vegetation area to impervious area cannot be achieved.</li> <li><input checked="" type="checkbox"/> A minimum forested or native vegetation flowpath length of 100 feet (25 feet for sheet flow from a non-native pervious surface) cannot be achieved.</li> </ul>	
Permeable Pavement List #1 and #2	<p>Citation of any of the following infeasibility criteria must be based on an evaluation of site-specific conditions and a written recommendation from an appropriate licensed professional (e.g., engineer, geologist, hydrogeologist):</p> <ul style="list-style-type: none"> <li><input type="checkbox"/> Where professional geotechnical evaluation recommends infiltration not be used due to reasonable concerns about erosion, slope failure, or downgradient flooding.</li> <li><input type="checkbox"/> Within an area whose ground water drains into an erosion hazard, or landslide hazard area.</li> <li><input type="checkbox"/> Where infiltrating and ponded water below the new permeable pavement area would compromise adjacent impervious pavements.</li> <li><input type="checkbox"/> Where infiltrating water below a new permeable pavement area would threaten existing below grade basements.</li> <li><input type="checkbox"/> Where infiltrating water would threaten shoreline structures such as bulkheads.</li> <li><input type="checkbox"/> Down slope of steep, erosion prone areas that are likely to deliver sediment.</li> <li><input type="checkbox"/> Where fill soils are used that can become unstable when saturated.</li> <li><input type="checkbox"/> Excessively steep slopes where water within the aggregate base layer or at the subgrade surface cannot be controlled by detention structures and may cause erosion and structural failure, or where surface runoff velocities may preclude adequate infiltration at the pavement surface.</li> <li><input type="checkbox"/> Where permeable pavements cannot provide sufficient strength to support heavy loads at industrial facilities such as ports.</li> <li><input type="checkbox"/> Where installation of permeable pavement would threaten the safety or reliability of pre-existing underground utilities, pre-existing underground storage tanks, or pre-existing road subgrades.</li> </ul>	



# CITY OF MERCER ISLAND

## SECTION C: INFEASIBILITY CRITERIA

Other Hard Surfaces (cont.)		
BMP and Applicable Lists	Infeasibility Criteria	Infeasibility Description and Rationale for Each BMP Not Selected
Permeable Pavement (cont.)	<p>The following criteria can be cited as reasons for infeasibility without further justification (though some require professional services to make the observation):</p> <ul style="list-style-type: none"> <li><input checked="" type="checkbox"/> Evaluation of infiltration is not required per the Infiltration Infeasibility Map due to steep slopes, erosion hazards, or landslide hazards</li> <li><input type="checkbox"/> Within an area designated as an erosion hazard, or landslide hazard.</li> <li><input type="checkbox"/> Within 50 feet from the top of slopes that are greater than 20 percent.</li> <li><input type="checkbox"/> For properties with known soil or groundwater contamination (typically federal Superfund sites or state cleanup sites under MTCA):               <ul style="list-style-type: none"> <li>• Within 100 feet of an area known to have deep soil contamination.</li> <li>• Where groundwater modeling indicates infiltration will likely increase or change the direction of the migration of pollutants in the groundwater.</li> <li>• Wherever surface soils have been found to be contaminated unless those soils are removed within 10 horizontal feet from the infiltration area.</li> <li>• Any area where these facilities are prohibited by an approved cleanup plan under the state MTCA or Federal Superfund Law, or an environmental covenant under Chapter 64.70 RCW.</li> </ul> </li> <li><input type="checkbox"/> Within 100 feet of a closed or active landfill.</li> <li><input type="checkbox"/> Within 100 feet of a drinking water well, or a spring used for drinking water supply, if the pavement is a pollution-generating surface.</li> <li><input type="checkbox"/> Within 10 feet of a small on-site sewage disposal drainfield, including reserve areas, and grey water reuse systems. For setbacks from a "large on-site sewage disposal system," see Chapter 246-272B WAC.</li> <li><input type="checkbox"/> Within 10 feet of any underground storage tank and connecting underground pipes, regardless of tank size. As used in these criteria, an underground storage tank means any tank used to store petroleum products, chemicals, or liquid hazardous wastes of which 10 percent or more of the storage volume (including volume in the connecting piping system) is beneath the ground surface.</li> <li><input type="checkbox"/> At multi-level parking garages, and over culverts and bridges.</li> <li><input type="checkbox"/> Where the site design cannot avoid putting pavement in areas likely to have long-term excessive sediment deposition after construction (e.g., construction and landscaping material yards).</li> </ul>	



# CITY OF MERCER ISLAND

## SECTION C: INFEASIBILITY CRITERIA

Other Hard Surfaces (cont.)		
BMP and Applicable Lists	Infeasibility Criteria	Infeasibility Description and Rationale for Each BMP Not Selected
Permeable Pavement (cont.)	<p>The following criteria can be cited as reasons for infeasibility without further justification (though some require professional services to make the observation):</p> <ul style="list-style-type: none"> <li><input type="checkbox"/> Where the site cannot reasonably be designed to have:               <ul style="list-style-type: none"> <li>• Porous asphalt surface &lt; 5% slope</li> <li>• Pervious concrete surface &lt; 10% slope</li> <li>• Permeable interlocking concrete pavement surface &lt; 12% slope</li> <li>• Grid systems &lt; 6-12% slope (check with manufacturer and local supplier to confirm maximum slope)</li> </ul> </li>   <li><input type="checkbox"/> Where the subgrade soils below a pollution-generating permeable pavement (e.g., road or parking lot) do not meet the soil suitability criteria for providing treatment. See soil suitability criteria for treatment in the <b>Stormwater Manual</b> Volume III, Section 3.3.7. Note: In these instances, the city may approve installation of a 6 inch sand filter layer meeting city specifications for treatment as a condition of construction.</li>   <li><input type="checkbox"/> Where underlying soils are unsuitable for supporting traffic loads when saturated. Soils meeting a California Bearing Ratio of 5 percent are considered suitable for residential access roads.</li>   <li><input type="checkbox"/> Where replacing existing impervious surfaces unless the existing surface is a non-pollution generating surface over an outwash soil with a saturated hydraulic conductivity of 4 inches per hour or greater.</li>   <li><input type="checkbox"/> Where appropriate field testing indicates soils have a measured (a.k.a., initial) subgrade soil saturated hydraulic conductivity less than 0.3 inches per hour. Only small-scale PIT or large-scale PIT methods in accordance with <b>Stormwater Manual</b> Volume III, Section 3.3.6 (or an alternative small scale test specified by the City) shall be used to evaluate infeasibility of permeable pavement areas. (Note: In these instances, unless other infeasibility restrictions apply, roads and parking lots may be built with an underdrain, preferably elevated within the base course, if flow control benefits are desired.)</li>   <li><input type="checkbox"/> Roads that receive more than very low traffic volumes, and areas having more than very low truck traffic. Roads with a projected average daily traffic volume of 400 vehicles or less are very low volume roads (AASHTO 2001) (U.S. Department of Transportation, 2013). Areas with very low truck traffic volumes are roads and other areas not subject to through truck traffic but may receive up to weekly use by utility trucks (e.g., garbage, recycling), daily school bus use, and multiple daily use by pick-up trucks, mail/parcel delivery trucks, and maintenance vehicles. (Note: This infeasibility criterion does not extend to sidewalks and other non-traffic bearing surfaces associated with the collector or arterial).</li> </ul>	



# CITY OF MERCER ISLAND

## SECTION C: INFEASIBILITY CRITERIA

Other Hard Surfaces (cont.)		
BMP and Applicable Lists	Infeasibility Criteria	Infeasibility Description and Rationale for Each BMP Not Selected
Permeable Pavement (cont.)	<p>The following criteria can be cited as reasons for infeasibility without further justification (though some require professional services to make the observation):</p> <ul style="list-style-type: none"> <li><input type="checkbox"/> At sites defined as “high-use sites” (refer to the Glossary in the <b>Stormwater Manual</b> Volume I).</li> <li><input type="checkbox"/> In areas with “industrial activity” as identified in 40 CFR 122.26(b)(14).</li> <li><input type="checkbox"/> Where the risk of concentrated pollutant spills is more likely such as gas stations, truck stops, and industrial chemical storage sites.</li> <li><input type="checkbox"/> Where routine, heavy applications of sand occur in frequent snow zones to maintain traction during weeks of snow and ice accumulation.</li> <li><input type="checkbox"/> Where the seasonal high groundwater or an underlying impermeable/low permeable layer would create saturated conditions within 1 foot of the bottom of the lowest gravel base course.</li> </ul>	
Bioretention or Rain Gardens  List #1 (both) and List #2 (bioretention only)	<p><i>Note: Criteria with setback distances are as measured from the bottom edge of the bioretention soil mix.</i></p> <p>Citation of any of the following infeasibility criteria must be based on an evaluation of site-specific conditions and a written recommendation from an appropriate licensed professional (e.g., engineer, geologist, hydrogeologist):</p> <ul style="list-style-type: none"> <li><input type="checkbox"/> Where professional geotechnical evaluation recommends infiltration not be used due to reasonable concerns about erosion, slope failure, or down-gradient flooding.</li> <li><input type="checkbox"/> Within an area whose ground water drains into an erosion hazard, or landslide hazard area.</li> <li><input type="checkbox"/> Where the only area available for siting would threaten the safety or reliability of pre-existing underground utilities, pre-existing underground storage tanks, pre-existing structures, or pre-existing road or parking lot surfaces.</li> <li><input type="checkbox"/> Where the only area available for siting does not allow for a safe overflow pathway to stormwater drainage system or private storm sewer system.</li> <li><input type="checkbox"/> Where there is a lack of usable space for bioretention areas at re-development sites, or where there is insufficient space within the existing public right-of-way on public road projects.</li> <li><input type="checkbox"/> Where infiltrating water would threaten existing below grade basements.</li> <li><input type="checkbox"/> Where infiltrating water would threaten shoreline structures such as bulkheads.</li> </ul>	



# CITY OF MERCER ISLAND

## SECTION C: INFEASIBILITY CRITERIA

Other Hard Surfaces (cont.)		
BMP and Applicable Lists	Infeasibility Criteria	Infeasibility Description and Rationale for Each BMP Not Selected
Bioretention or Rain Gardens (cont.)	<p>The following criteria can be cited as reasons for infeasibility without further justification (though some require professional services to make the observation):</p> <ul style="list-style-type: none"> <li><input checked="" type="checkbox"/> Where evaluation of infiltration is not required per the Infiltration Infeasibility Map due to steep slopes, erosion hazards, or landslide hazards.</li> <li><input type="checkbox"/> Within setback provided for BMP T7.30 (<b>Stormwater Manual</b> Volume V, Section 7.4)</li> <li><input type="checkbox"/> Where they are not compatible with surrounding drainage system as determined by the city (e.g., project drains to an existing stormwater collection system whose elevation or location precludes connection to a properly functioning bioretention area).</li> <li><input type="checkbox"/> Where land for bioretention is within an erosion hazard, or landslide hazard area (as defined by MICC 19.07.060).</li> <li><input type="checkbox"/> Where the site cannot be reasonably designed to locate bioretention areas on slopes less than 8 percent.</li> <li><input type="checkbox"/> Within 50 feet from the top of slopes that are greater than 20 percent and over 10 feet of vertical relief.</li> <li><input type="checkbox"/> For properties with known soil or groundwater contamination (typically federal Superfund sites or state cleanup sites under the Model Toxics Control Act [MTCA]):               <ul style="list-style-type: none"> <li>• Within 100 feet of an area known to have deep soil contamination.</li> <li>• Where groundwater modeling indicates infiltration will likely increase or change the direction of the migration of pollutants in the groundwater.</li> <li>• Wherever surface soils have been found to be contaminated unless those soils are removed within 10 horizontal feet from the infiltration area.</li> <li>• Any area where these facilities are prohibited by an approved cleanup plan under the state MTCA or Federal Superfund Law, or an environmental covenant under Chapter 64.70 RCW.</li> </ul> </li> <li><input type="checkbox"/> Within 100 feet of a closed or active landfill.</li> <li><input type="checkbox"/> Within 10 feet of an underground storage tank and connecting underground pipes when the capacity of the tank and pipe system is 1,100 gallons or less. As used in these criteria, an underground storage tank means any tank used to store petroleum products, chemicals, or liquid hazardous wastes of which 10 percent or more of the storage volume (including volume in the connecting piping system) is beneath the ground surface.</li> </ul>	



# CITY OF MERCER ISLAND

## SECTION C: INFEASIBILITY CRITERIA

Other Hard Surfaces (cont.)		
BMP and Applicable Lists	Infeasibility Criteria	Infeasibility Description and Rationale for Each BMP Not Selected
Bioretention or Rain Gardens (cont.)	<p>The following criteria can be cited as reasons for infeasibility without further justification (though some require professional services to make the observation):</p> <ul style="list-style-type: none"> <li><input type="checkbox"/> Within 100 feet of an underground storage tank and connecting underground pipes when the capacity of the tank and pipe system is greater than 1,100 gallons.</li> <li><input type="checkbox"/> Where field testing indicates potential bioretention/rain garden sites have a measured (a.k.a., initial) native soil saturated hydraulic conductivity less than 0.30 inches per hour. A small-scale or large-scale PIT in accordance with <b>Stormwater Manual</b> Volume III, Section 3.3.6 (or an alternative small scale test specified by the City) shall be used to demonstrate infeasibility of bioretention areas. If the measured native soil infiltration rate is less than 0.30 in/hour, bioretention/rain garden BMPs are not required to be evaluated as an option in List #1 or List #2. In these slow draining soils, a bioretention area with an underdrain may be used to treat pollution-generating surfaces to help meet Minimum Requirement #6, Runoff Treatment. If the underdrain is elevated within a base course of gravel, it will also provide some modest flow reduction benefit that will help achieve Minimum Requirement #7.</li> <li><input type="checkbox"/> Where the minimum vertical separation of 3 feet to the seasonal high groundwater elevation or other impermeable layer would not be achieved below bioretention that would serve a drainage area that exceeds the following thresholds (and cannot reasonably be broken down into amounts smaller than indicated):               <ul style="list-style-type: none"> <li>o 5,000 square feet of pollution-generating impervious surface (PGIS)</li> <li>o 10,000 square feet of impervious area</li> <li>o 0.75 acres of lawn and landscape.</li> </ul> </li> <li><input type="checkbox"/> Where the minimum vertical separation of 1 foot to the seasonal high groundwater or other impermeable layer would not be achieved below bioretention that would serve a drainage area less than the above thresholds</li> <li><input type="checkbox"/> Within 100 feet of a drinking water well, or a spring used for drinking water supply.</li> <li><input type="checkbox"/> Within 10 feet of small on-site sewage disposal drainfield, including reserve areas, and grey water reuse systems. For setbacks from a "large on-site sewage disposal system," see Chapter 246-272B WAC.</li> </ul>	





# CITY OF MERCER ISLAND

## SECTION C: INFEASIBILITY CRITERIA

Other Hard Surfaces (cont.)		
BMP and Applicable Lists	Infeasibility Criteria	Infeasibility Description and Rationale for Each BMP Not Selected
Sheet Flow Dispersion List #1 and #2	<input checked="" type="checkbox"/> Site setbacks and design criteria provided in BMP T5.12 ( <b>Stormwater Manual</b> Volume V, Section 5.3) cannot be achieved. <input type="checkbox"/> Positive drainage for sheet flow runoff cannot be achieved. <input type="checkbox"/> Area to be dispersed (e.g., driveway, patio) cannot be graded to have less than a 15 percent slope. <input type="checkbox"/> For flat to moderately sloped areas, at least a 10 foot-wide vegetation buffer for dispersion of the adjacent 20 feet of contributing surface cannot be achieved. For variably sloped areas, at least a 25 foot vegetated flowpath between berms cannot be achieved.	
Concentrated Flow Dispersion List #1 and #2	<input checked="" type="checkbox"/> Site setbacks and design criteria provided in BMP T5.11 ( <b>Stormwater Manual</b> Volume V, Section 5.3) cannot be achieved. <input type="checkbox"/> A minimum 3 foot length of rock pad and 50 foot flowpath OR a dispersion trench and 25 foot flowpath for every 700 square feet of drainage area followed with applicable setbacks cannot be achieved. <input type="checkbox"/> More than 700 square feet drainage area drains to any dispersion device.	
On-site Detention List #1 and #2	<input type="checkbox"/> Project discharges directly to Lake Washington. <input type="checkbox"/> Findings from a 1/4 mile downstream analysis confirm that the downstream system is free of capacity constraints. <input type="checkbox"/> Site setbacks and design criteria provided in the <b>Stormwater Manual</b> (Volume III, Section 3.2.2) cannot be achieved.	



# CITY OF MERCER ISLAND

## SECTION D: POST-CONSTRUCTION SOIL MANAGEMENT

### Attachments Required *(Check off required items that are attached)*

<input checked="" type="checkbox"/>	Site Plan showing, to scale:
<input type="checkbox"/>	Areas of undisturbed native vegetation (no amendment required)
<input type="checkbox"/>	New planting beds (amendment required)
<input type="checkbox"/>	New turf areas (amendment required)
<input type="checkbox"/>	Type of soil improvement proposed for each area
<input type="checkbox"/>	Soil test results (required if proposing custom amendment rates)
<input type="checkbox"/>	Product test results for proposed amendments

### Total Amendment / Topsoil / Mulch for All Areas

Calculate the quantities needed for the entire site based on all of the areas identified on the Site Plan and the calculations on the following page(s):

Product	Total Quantity (CY)	Test Results
Product #1: _____	_____ CY	_____ % organic matter _____ C:N ratio "Stable"?    yes <input type="checkbox"/> no <input type="checkbox"/>
Product #2: _____	_____ CY	_____ % organic matter _____ C:N ratio "Stable"?    yes <input type="checkbox"/> no <input type="checkbox"/>
Product #3: _____	_____ CY	_____ % organic matter _____ C:N ratio "Stable"?    yes <input type="checkbox"/> no <input type="checkbox"/>

CY = cubic yards, C:N = Carbon:Nitrogen



# CITY OF MERCER ISLAND

## SECTION D: POST-CONSTRUCTION SOIL MANAGEMENT

### Amendment / Topsoil / Mulch by Area

For each identified area on your Site Plan, provide the following information: (Use additional sheets if necessary)

Area # \_\_\_\_\_ (should match identified Area # on Site Plan)

Planting type:  Turf  Undisturbed native vegetation  
 Planting Beds  Other: \_\_\_\_\_

### Pre-Approved Amendment Method

<input type="checkbox"/>	Amend with compost	Turf: _____ SF x 5.4 CY ÷ 1,000 SF = _____ CY Planting beds: _____ SF x 9.3 CY ÷ 1,000 SF = _____ CY Total Quantity = _____ CY Scarification depth: 8 inches	Product: _____
<input type="checkbox"/>	Stockpile and amend	Turf: _____ SF x 5.4 CY ÷ 1,000 SF = _____ CY Planting beds: _____ SF x 9.3 CY ÷ 1,000 SF = _____ CY Total Quantity = _____ CY Scarification depth: 8 inches	Product: _____
<input type="checkbox"/>	Topsoil import	Turf: _____ SF x 18.6 CY ÷ 1,000 SF = _____ CY Planting beds: _____ SF x 18.6 CY ÷ 1,000 SF = _____ CY Total Quantity = _____ CY Scarification depth: 6 inches	Product: _____

### Custom Amendment

<input type="checkbox"/>	Amend with compost	Attach information on bulk density, percent organic matter, moisture content, C:N ratio, and heavy metals analysis to support custom amendment rate and scarification depth. Total Quantity = _____ CY Scarification depth: _____ inches	Product: _____
<input type="checkbox"/>	Stockpile and amend	Attach information on bulk density, percent organic matter, moisture content, C:N ratio, and heavy metals analysis to support custom amendment rate and scarification depth. Total Quantity = _____ CY Scarification depth: _____ inches	Product: _____

### Mulch

<input type="checkbox"/>	Amend with compost	Planting beds: _____ SF x 12.4 CY ÷ 1,000 SF = _____ CY Total Quantity = _____ CY	Product: _____
<input type="checkbox"/>	Stockpile and amend	Planting beds: _____ SF x 12.4 CY ÷ 1,000 SF = _____ CY Total Quantity = _____ CY	Product: _____
<input type="checkbox"/>	Topsoil import	Planting beds: _____ SF x 12.4 CY ÷ 1,000 SF = _____ CY Total Quantity = _____ CY	Product: _____

CY = cubic yards, C:N = Carbon:Nitrogen



# CITY OF MERCER ISLAND

## SECTION E: SIGNATURE PAGE

### **Project Engineer’s Certification for Section B**

For Stormwater Site Plans with engineered elements, the Construction SWPPP is stamped by a professional engineer licensed in the State of Washington in civil engineering.

If required, attach a page with the project engineer’s seal with the following statement:

Knotz Remodel

*“I hereby state that this Construction Stormwater Pollution Prevention Plan for \_\_\_\_\_  
(name of project)  
has been prepared by me or under my supervision and meets the standard of care and expertise which is usual and customary in this community for professional engineers. I understand that the City of Mercer Island does not and will not assume liability for the sufficiency, suitability, or performance of Construction SWPPP BMPs prepared by me.”*

### **Applicant Signature for Full Stormwater Package (Sections A through D)**

I have read and completed the Stormwater Submittal Package and know the information provided to be true and correct.

Print Applicant Name: Nick Bossoff \_\_\_\_\_

Applicant Signature: \_\_\_\_\_ Date 10/17/2022 \_\_\_\_\_

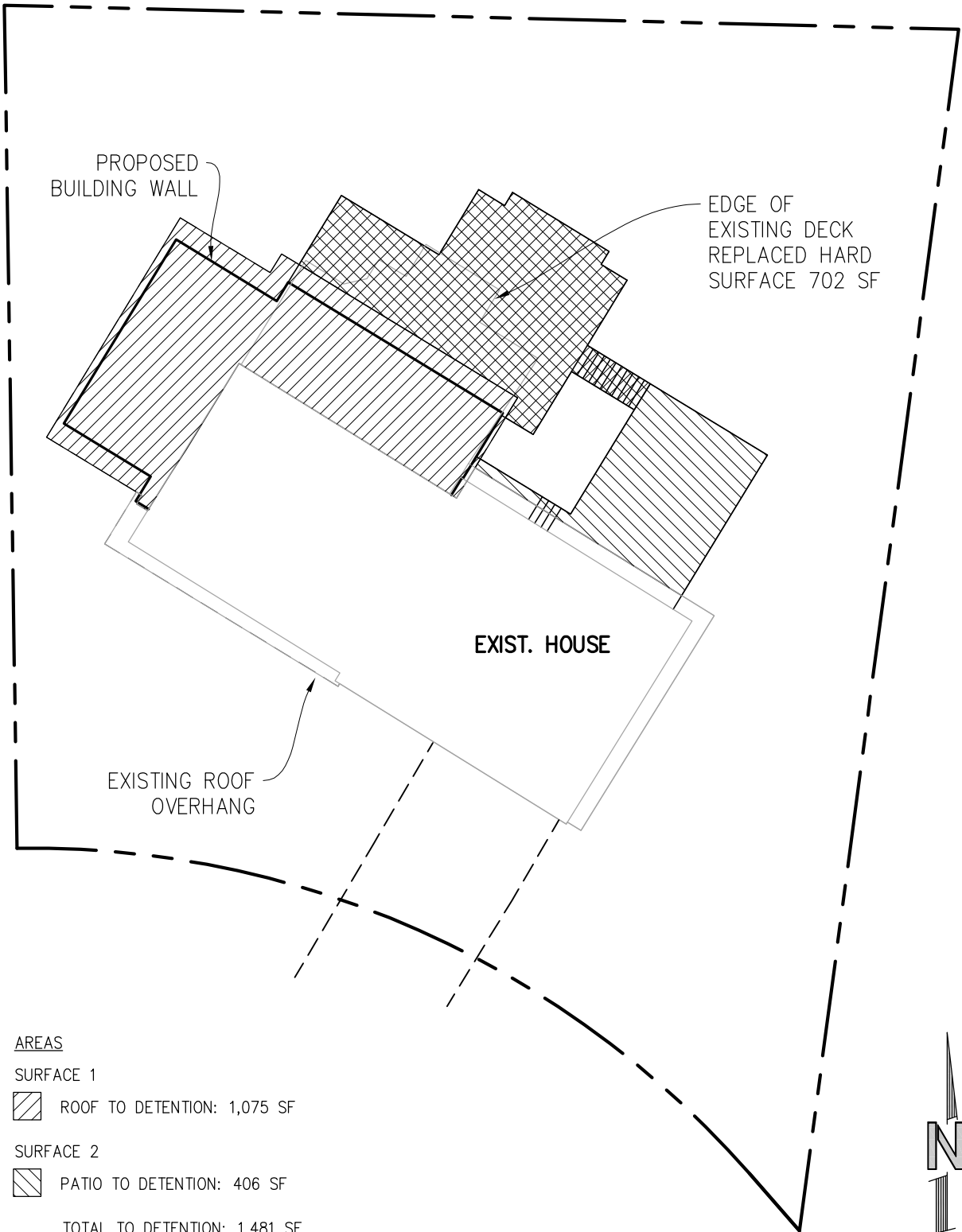

AREAS

SURFACE 1

 ROOF TO DETENTION: 1,075 SF

SURFACE 2

 PATIO TO DETENTION: 406 SF

TOTAL TO DETENTION: 1,481 SF

SURFACE 3

 DRIP-THROUGH DECK: 709 SF

TOTAL NEW/REPLACED: 2,190 SF

REPLACED: 702 SF

NEW: 1,488 SF





































# NEW/REPLACED HARD SURFACES

Soil Map—King County Area, Washington  
(6020 94th Avenue SE)



Soil Map—King County Area, Washington  
(6020 94th Avenue SE)

### MAP LEGEND

<b>Area of Interest (AOI)</b>			Spoil Area
	Area of Interest (AOI)		Stony Spot
<b>Soils</b>			Very Stony Spot
	Soil Map Unit Polygons		Wet Spot
	Soil Map Unit Lines		Other
	Soil Map Unit Points		Special Line Features
<b>Special Point Features</b>		<b>Water Features</b>	
	Blowout		Streams and Canals
	Borrow Pit	<b>Transportation</b>	
	Clay Spot		Rails
	Closed Depression		Interstate Highways
	Gravel Pit		US Routes
	Gravelly Spot		Major Roads
	Landfill		Local Roads
	Lava Flow	<b>Background</b>	
	Marsh or swamp		Aerial Photography
	Mine or Quarry		
	Miscellaneous Water		
	Perennial Water		
	Rock Outcrop		
	Saline Spot		
	Sandy Spot		
	Severely Eroded Spot		
	Sinkhole		
	Slide or Slip		
	Sodic Spot		

### MAP INFORMATION

The soil surveys that comprise your AOI were mapped at 1:24,000.

Warning: Soil Map may not be valid at this scale.  
Enlargement of maps beyond the scale of mapping can cause misunderstanding of the detail of mapping and accuracy of soil line placement. The maps do not show the small areas of contrasting soils that could have been shown at a more detailed scale.

Please rely on the bar scale on each map sheet for map measurements.

Source of Map: Natural Resources Conservation Service  
Web Soil Survey URL:  
Coordinate System: Web Mercator (EPSG:3857)

Maps from the Web Soil Survey are based on the Web Mercator projection, which preserves direction and shape but distorts distance and area. A projection that preserves area, such as the Albers equal-area conic projection, should be used if more accurate calculations of distance or area are required.

This product is generated from the USDA-NRCS certified data as of the version date(s) listed below.

Soil Survey Area: King County Area, Washington  
Survey Area Data: Version 17, Aug 23, 2021

Soil map units are labeled (as space allows) for map scales 1:50,000 or larger.

Date(s) aerial images were photographed: Jul 6, 2020—Jul 20, 2020

The orthophoto or other base map on which the soil lines were compiled and digitized probably differs from the background imagery displayed on these maps. As a result, some minor shifting of map unit boundaries may be evident.

## Map Unit Legend

Map Unit Symbol	Map Unit Name	Acres in AOI	Percent of AOI
AgC	Alderwood gravelly sandy loam, 8 to 15 percent slopes	2.2	6.4%
AmB	Arents, Alderwood material, 0 to 6 percent slopes	7.1	20.5%
KpD	Kitsap silt loam, 15 to 30 percent slopes	25.2	73.1%
<b>Totals for Area of Interest</b>		<b>34.4</b>	<b>100.0%</b>



STORMWATER MANAGEMENT MANUAL FOR THE PUGET SOUND BASIN

Table III-1.6 Hydrologic Soil Groups for Soils in the Puget Sound Basin

Soil Type	Hydrologic Soil Group	Soil Type	Hydrologic Soil Group
Agnew	C	Colter	C
Ahl	B	Custer	ND
Aits	C	Dabob	ND
Alderwood	C	Delphi	D
Arents, Alderwood	B	Dick	ND
Arents, Everett	B	Dimal	D
Ashoe	B	Dupont	D
Baldhill	B	Earlmont	C
Barneston	C	Edgewick	C
Baumgard	B	Eld	B
Beausite	B	Elwell	B
Belfast	C	Esquatzel	B
Bellingham	D	Everett	A
Bellingham variant	C	Everson	D
Boistfort	B	Galvin	D
Bow	D	Getchell	A
Briscot	D	Giles	B
Buckley	C	Godfrey	D
Bunker	B	Greenwater	A
Cagey	C	Grove	C
Carlsborg	ND	Harstine	C
Casey	ND	Hartnit	ND
Cassolary	C	Hoh	ND
Cathcart	B	Hoko	ND
Centralia	B	Hoodsport	ND
Chehalis	B	Hoogdal	C
Chesaw	A	Hoypus	ND
Cinebar	B	Huel	ND
Clallam	C	Indianola	ND
Clayton	B	Jonas	B
Coastal beaches	variable	Junpe	ND
Kapowsin	C/D	Kalaloch	C
Katula	C	Renton	D
Kitchie	C	Republic	B
Kitsap	C	Riverwash	variable
Klaus	ND	Rober	C
Klone	ND	Salal	C
Lates	C	Salkum	B
Lebam	B	Sammamish	D
Lummi	ND	San Juan	ND
Lynnwood	ND	Scamman	D
Lystair	ND	Schneider	B
Mal	C	Seattle	D
Manley	B	Sekiu	ND
Mashel	B	Semiahmoo	D
Maytown	C	Shalcar	D
McKenna	D	Shano	B
McMurray	ND	Shelton	C
Melbourne	B	Si	C
Menzel	ND	Sinclair	C
Mixed Alluvial	variable	Skipopa	D
Molson	B	Skykomish	B
Mukilteo	C/D	Snahopish	ND
Naff	B	Snohomish	D
Nargar	A	Solduc	B
National	ND	Solleks	ND
Neilton	A	Spana	D

**Table 1**

ON-SITE DETENTION DESIGN FOR PROJECTS BETWEEN 500 SF AND 9,500 SF NEW PLUS REPLACED IMPERVIOUS SURFACE AREA

New and Replaced Impervious Surface Area (sf)	Detention Pipe Diameter (in)	Detention Pipe Length (ft)		Lowest Orifice Diameter (in) <sup>(3)</sup>		Distance from Outlet Invert to Second Orifice (ft)		Second Orifice Diameter (in)	
		B soils	C soils	B soils	C soils	B soils	C soils	B soils	C soils
500 to 1,000 sf	36"	30	22	0.5	0.5	2.2	2.0	0.5	0.8
	48"	18	11	0.5	0.5	3.3	3.2	0.9	0.8
	60"	11	7	0.5	0.5	4.2	3.4	0.5	0.6
1,001 to 2,000 sf	36"	66	43	0.5	0.5	2.2	2.3	0.9	1.4
	48"	34	23	0.5	0.5	3.2	3.3	0.9	1.2
	60"	22	14	0.5	0.5	4.3	3.6	0.9	0.9
2,001 to 3,000 sf	36"	90	66	0.5	0.5	2.2	2.4	0.9	1.9
	48"	48	36	0.5	0.5	3.1	2.8	0.9	1.5
	60"	30	20	0.5	0.5	4.2	3.7	0.9	1.1
3,001 to 4,000 sf	36"	120	78	0.5	0.5	2.4	2.2	1.4	1.6
	48"	62	42	0.5	0.5	2.8	2.9	0.8	1.3
	60"	42	26	0.5	0.5	3.8	3.9	0.9	1.3
4,001 to 5,000 sf	36"	134	91	0.5	0.5	2.8	2.2	1.7	1.5
	48"	73	49	0.5	0.5	3.6	2.9	1.6	1.5
	60"	46	31	0.5	0.5	4.6	3.5	1.6	1.3
5,001 to 6,000 sf	36"	162	109	0.5	0.5	2.7	2.2	1.8	1.6
	48"	90	59	0.5	0.5	3.5	2.9	1.7	1.5
	60"	54	37	0.5	0.5	4.6	3.6	1.6	1.4
6,001 to 7,000 sf	36"	192	128	0.5	0.5	2.7	2.2	1.9	1.8
	48"	102	68	0.5	0.5	3.7	2.9	1.9	1.6
	60"	64	43	0.5	0.5	4.6	3.6	1.8	1.5
7,001 to 8,000 sf	36"	216	146	0.5	0.5	2.8	2.2	2.0	1.9
	48"	119	79	0.5	0.5	3.8	2.9	2.2	1.7
	60"	73	49	0.5	0.5	4.5	3.6	2.0	1.6
8,001 to 8,500 sf <sup>(1)</sup>	36"	228	155	0.5	0.5	2.8	2.2	2.1	1.9
	48"	124	84	0.5	0.5	3.7	2.9	1.9	1.8
	60"	77	53	0.5	0.5	4.6	3.6	2.0	1.6
8,501 to 9,000 sf	36"	NA <sup>(1)</sup>	164	0.5	0.5	NA <sup>(1)</sup>	2.2	NA <sup>(1)</sup>	1.9
	48"	NA <sup>(1)</sup>	89	0.5	0.5	NA <sup>(1)</sup>	2.9	NA <sup>(1)</sup>	1.9
	60"	NA <sup>(1)</sup>	55	0.5	0.5	NA <sup>(1)</sup>	3.6	NA <sup>(1)</sup>	1.7
9,001 to 9,500 sf <sup>(2)</sup>	36"	NA <sup>(1)</sup>	174	0.5	0.5	NA <sup>(1)</sup>	2.2	NA <sup>(1)</sup>	2.1
	48"	NA <sup>(1)</sup>	94	0.5	0.5	NA <sup>(1)</sup>	2.9	NA <sup>(1)</sup>	2.0
	60"	NA <sup>(1)</sup>	58	0.5	0.5	NA <sup>(1)</sup>	3.7	NA <sup>(1)</sup>	1.7

**Notes:**

▪ Minimum Requirement #7 (Flow Control) is required when the 100-year flow frequency causes a 0.15 cubic feet per second increase (when modeled in WWHM with a 15-minute timestep). Breakpoints shown in this table are based on a flat slope (0-5%). The 100-year flow frequency will need to be evaluated on a site-specific basis for projects on moderate (5-15%) or steep (> 15%) slopes.

- Soil type to be determined by geotechnical analysis or soil map.
- Sizing includes a Volume Correction Factor of 120%.
- Upper bound contributing area used for sizing.

<sup>(1)</sup> On Type B soils, new plus replaced impervious surface areas exceeding 8,500 sf trigger Minimum Requirement #7 (Flow Control)

<sup>(2)</sup> On Type C soils, new plus replaced impervious surface areas exceeding 9,500 sf trigger Minimum Requirement #7 (Flow Control)

<sup>(3)</sup> Minimum orifice diameter = 0.5 inches

in = inch

ft = feet

sf = square feet

**Basis of Sizing Assumptions:**

Sized per MR#5 in the Stormwater Management Manual for Puget Sound Basin (1992 Ecology Manual)

SBUH, Type 1A, 24-hour hydrograph

2-year, 24-hour storm = 2 in; 10-year, 24-hour storm = 3 in; 100-year, 24-hour storm = 4 in

Predeveloped = second growth forest (CN = 72 for Type B soils, CN = 81 for Type C soils)

Developed = impervious (CN = 98)

0.5 foot of sediment storage in detention pipe

Overland slope = 5%



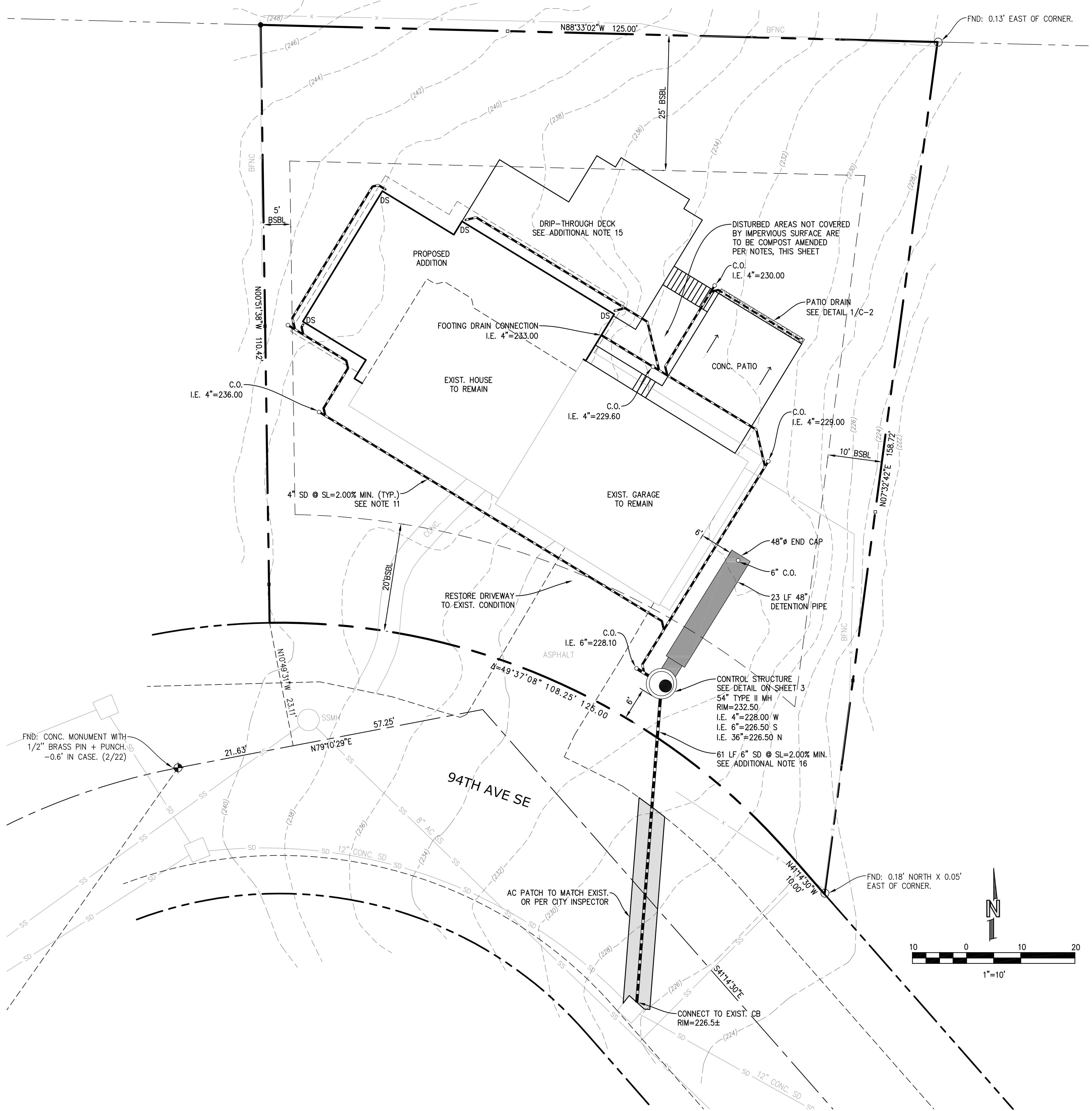

**POST-CONSTRUCTION SOIL QUALITY AND DEPTH NOTES**

- A. SOIL RETENTION. RETAIN, IN AN UNDISTURBED STATE, THE DUFF LAYER AND NATIVE TOPSOIL TO THE MAXIMUM EXTENT PRACTICABLE. IN ANY AREAS REQUIRING GRADING REMOVE AND STOCKPILE THE DUFF LAYER AND TOPSOIL ON SITE IN A DESIGNATED, CONTROLLED AREA, NOT ADJACENT TO PUBLIC RESOURCES AND CRITICAL AREAS, TO BE REAPPLIED TO OTHER PORTIONS OF THE SITE WHERE FEASIBLE.
- B. SOIL QUALITY. ALL AREAS SUBJECT TO CLEARING AND GRADING THAT HAVE NOT BEEN COVERED BY IMPERVIOUS SURFACE, INCORPORATED INTO A DRAINAGE FACILITY OR ENGINEERED AS STRUCTURAL FILL OR SLOPE SHALL, AT PROJECT COMPLETION, DEMONSTRATE THE FOLLOWING:
  1. A TOPSOIL LAYER WITH A MINIMUM ORGANIC MATTER CONTENT OF 10% DRY WEIGHT IN PLANTING BEDS, AND 5% ORGANIC MATTER CONTENT IN TURF AREAS, AND A PH FROM 6.0 TO 8.0 OR MATCHING THE PH OF THE UNDISTURBED SOIL. THE TOPSOIL LAYER SHALL HAVE A MINIMUM DEPTH OF EIGHT INCHES EXCEPT WHERE TREE ROOTS LIMIT THE DEPTH OF INCORPORATION OF AMENDMENTS NEEDED TO MEET THE CRITERIA. SUBSOILS BELOW THE TOPSOIL LAYER SHOULD BE SCARIFIED AT LEAST 4 INCHES WITH SOME INCORPORATION OF THE UPPER MATERIAL TO AVOID STRATIFIED LAYERS, WHERE FEASIBLE.
  2. MULCH PLANTING BEDS WITH 2 INCHES OF ORGANIC MATERIAL.
  3. USE COMPOST AND OTHER MATERIALS THAT MEET THESE ORGANIC CONTENT REQUIREMENTS:
    - A. THE ORGANIC CONTENT FOR "PRE-APPROVED" AMENDMENT RATES CAN BE MET ONLY USING COMPOST MEETING THE DEFINITION OF "COMPOSTED MATERIALS" IN WAC 173-350-220, WITH THE EXCEPTION THAT THE COMPOST MAY HAVE UP TO 35% BIOSOLIDS OR MANURE. THE COMPOST MUST ALSO HAVE AN ORGANIC MATTER CONTENT OF 40% TO 65%, AND A CARBON TO NITROGEN RATIO BELOW 25:1. THE CARBON TO NITROGEN RATIO MAY BE AS HIGH AS 35:1 FOR PLANTINGS COMPOSED ENTIRELY OF PLANTS NATIVE TO THE PUGET SOUND LOWLANDS REGION.
    - B. CALCULATED AMENDMENT RATES MAY BE MET THROUGH USE OF COMPOSTED MATERIAL MEETING (A.) ABOVE; OR OTHER ORGANIC MATERIALS AMENDED TO MEET THE CARBON TO NITROGEN RATIO REQUIREMENTS, AND NOT EXCEEDING THE CONTAMINANT LIMITS IDENTIFIED IN TABLE 220-B, TESTING PARAMETERS, IN WAC 173-350-220.
- C. IMPLEMENTATION OPTIONS: THE SOIL QUALITY DESIGN GUIDELINES LISTED ABOVE CAN BE MET BY USING ONE OF THE METHODS LISTED BELOW:
  1. LEAVE UNDISTURBED NATIVE VEGETATION AND SOIL AND PROTECT FROM COMPACTION DURING CONSTRUCTION.
  2. AMEND EXISTING SITE TOPSOIL OR SUBSOIL EITHER AT DEFAULT "PREAPPROVED" RATES, OR AT CUSTOM CALCULATED RATES BASED ON TESTS OF THE SOIL AND AMENDMENT.
  3. STOCKPILE EXISTING TOPSOIL DURING GRADING AND REPLACE IT PRIOR TO PLANTING. STOCKPILED TOPSOIL MUST ALSO BE AMENDED IF NEEDED TO MEET THE ORGANIC MATTER OR DEPTH REQUIREMENTS, EITHER AT A DEFAULT "PRE-APPROVED" RATE OR AT A CUSTOM CALCULATED RATE.
  4. IMPORT TOPSOIL MIX OF SUFFICIENT ORGANIC CONTENT AND DEPTH TO MEET THE REQUIREMENTS. MORE THAN ONE METHOD MAY BE USED ON DIFFERENT PORTIONS OF THE SAME SITE. SOIL THAT ALREADY MEETS THE DEPTH AND ORGANIC MATTER QUALITY STANDARDS, AND IS NOT COMPACTED, DOES NOT NEED TO BE AMENDED.

**ADDITIONAL NOTES:**

1. ALL CONSTRUCTION MATERIALS AND PRACTICE SHALL CONFORM TO THE CITY OF MERCER ISLAND STANDARDS AND THE WASHINGTON STATE DEPARTMENT OF TRANSPORTATION STANDARDS.
2. EXISTING UTILITIES AS SHOWN ARE FROM CITY RECORDS AND ARE APPROXIMATE. IT SHALL BE THE CONTRACTOR'S RESPONSIBILITY TO IDENTIFY, LOCATE AND PROTECT ABOVE AND BELOW GRADE UTILITIES. CONTRACTOR SHALL NOTIFY THE ENGINEER PRIOR TO CONSTRUCTION IF A CONFLICT EXISTS BETWEEN EXISTING UTILITIES AND THE PROPOSED IMPROVEMENTS.
3. THE CONTRACTOR IS RESPONSIBLE FOR EROSION AND SEDIMENTATION CONTROL AND SHALL MAINTAIN THE NECESSARY SAFEGUARDS AND MANAGE THE CONSTRUCTION SO AS TO PREVENT WATERBORNE SEDIMENTS FROM LEAVING THE SITE.
4. THE CONTRACTOR SHALL BE RESPONSIBLE FOR PROVIDING ADEQUATE SAFEGUARDS, SAFETY DEVICES, PROTECTIVE EQUIPMENT, FLAGGERS, AND ANY OTHER NEEDED ACTIONS TO PROTECT THE LIFE, HEALTH, AND SAFETY OF THE PUBLIC, AND TO PROTECT PROPERTY IN CONNECTION WITH THE PERFORMANCE OF WORK COVERED BY THE CONTRACTOR.
5. ON-SITE PRIVATE STORM AND SEWER PIPE SHALL BE SOLVENT WELDED SCHEDULE 40 PVC OR PVC ASTM D3034 SDR35 UNLESS SHOWN OTHERWISE. PVC PIPE LAID AT A SLOPE IN EXCESS OF 20% SHALL BE SOLVENT WELDED SCHEDULE 40 PVC. STORM PIPE IN THE RIGHT-OF-WAY SHALL BE HIGH-DENSITY POLYETHYLENE DOUBLE-WALLED SMOOTH INTERIOR PIPE SUCH AS ADS N-12 OR EQUIVALENT.
6. FOOTING DRAINS SHALL BE INSTALLED AROUND THE BASE OF ALL FOUNDATION FOOTINGS THAT ENCLOSE A CRAWL SPACE, CELLAR, BASEMENT, GARAGE OR OTHER BUILDING SPACE. FOOTING DRAINS SHALL BE PERFORATED 4-INCH DIAMETER PVC CONFORMING TO D2729, PERFORATIONS DOWN. GRANULAR BACKFILL SHALL BE PLACED AROUND AND ABOVE THE DRAIN TO A DEPTH OF 2/3 OF THE WALL HEIGHT. FILTER FABRIC (MIRAFI 140N OR EQUIVALENT) SHALL BE PLACED BETWEEN THE GRANULAR BACKFILL AND NATIVE SOILS. TIE THE FOOTING DRAIN INTO THE STORM LINE AT A LOCATION WHERE THE FOOTING DRAIN ELEVATION IS AT LEAST 12-INCHES ABOVE THE STORM LINE.
7. EXISTING SIDE SEWER AND STORM DRAIN DEPTH AND LOCATION SHALL BE DETERMINED PRIOR TO ANY CONSTRUCTION, INCLUDING BUILDING CONSTRUCTION. REPORT CONFLICTS WITH PROPOSED CONSTRUCTION TO ENGINEER. NEW SIDE SEWER CONNECTION TO MAIN OR SEWER EJECTOR PUMP MAY BE NECESSARY FOR BASEMENT.
8. PROPOSED METER LOCATION, IF SHOWN, IS APPROXIMATE. CONTRACTOR TO COORDINATE EXACT LOCATION OF NEW SERVICE/METER/ SUPPLY LINE WITH CITY WATER DEPARTMENT DURING CONSTRUCTION.
9. EACH DOWNSPOUT SHALL CONNECT TO A RIGID NON-PERFORATED PIPE AT THE BUILDING PERIMETER. UNDER NO CIRCUMSTANCES SHALL DOWNSPOUTS CONNECT DIRECTLY TO THE PERFORATED FOOTING DRAIN.
10. USE SAND COLLARS FOR PVC PIPE CONNECTIONS TO MANHOLES.
11. VERTICAL BENDS ON THE STORM DRAINS MAY BE NECESSARY TO MAINTAIN MIN. 1.5' SOIL COVER OVER PIPE. MAX. PIPE BENDS TO BE 45'.
12. DOWNSPOUT LOCATIONS SHOWN ARE PRELIMINARY. REFER TO ARCHITECTURAL PLANS FOR FINAL DOWNSPOUT LOCATIONS.
13. AN UNDERSLAB DRAINAGE SYSTEM MAY BE NECESSARY DEPENDENT ON GEOTECHNICAL EVALUATION BY OTHERS.
14. WINDOW WELLS SHALL BE DESIGNED FOR PROPER DRAINAGE BY CONNECTING TO THE BUILDING'S FOUNDATION DRAINAGE SYSTEM REQUIRED PER SECTION R310.2.3.2 OF THE INTERNATIONAL RESIDENTIAL CODE. A DRAINAGE SYSTEM FOR WINDOW WELLS IS NOT REQUIRED WHERE THE FOUNDATION IS ON WELL-DRAINED SOIL OR SAND-GRAVEL MIXTURE SOILS IN ACCORDANCE WITH THE UNITED SOIL CLASSIFICATION SYSTEM, GROUP 1 SOILS, AS DETAILED IN TABLE R405.1 OF THE IRC.
15. THE OPENINGS IN THE DECKING OF THE DECK AND STAIRS SHALL BE AT LEAST 10% OF THE SURFACE AREA AND MUST BE EVENLY DISTRIBUTED ACROSS THE SURFACE SUCH THAT THERE ARE AT LEAST 2 OPENINGS PER SQUARE FOOT. THE SOIL BELOW SHALL BE AMENDED AND COVERED BY MULCH PER THE POST CONSTRUCTION SOIL QUALITY NOTES ON THIS SHEET FOR THE FULL EXTENT OF THE DECKING.
16. THE EXISTING DRAINAGE SYSTEM SHALL BE INVESTIGATED TO DETERMINE IF THERE IS AN EXISTING CONNECTION TO THE CITY STORM DRAIN. THE CONNECTION PIPE, IF ANY, SHALL BE VIDEOED AND THE CONDITION ASSESSED BY THE PROJECT ENGINEER. IF THE CONNECTION IS VIABLE IN TERMS OF GRADES, CONDITION, AND CAPACITY, AND MEETS CITY STANDARDS, A NEW CONNECTION WILL NOT BE NECESSARY.

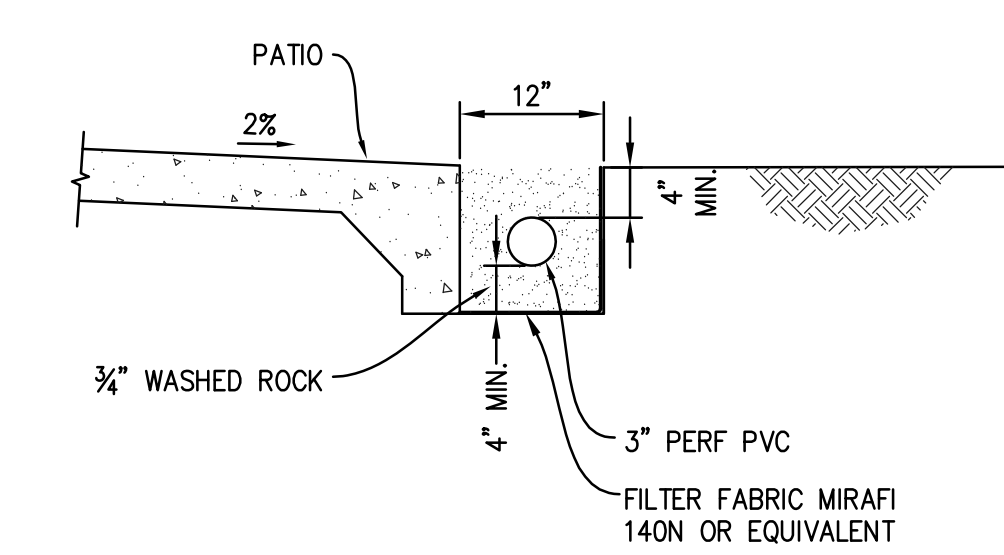
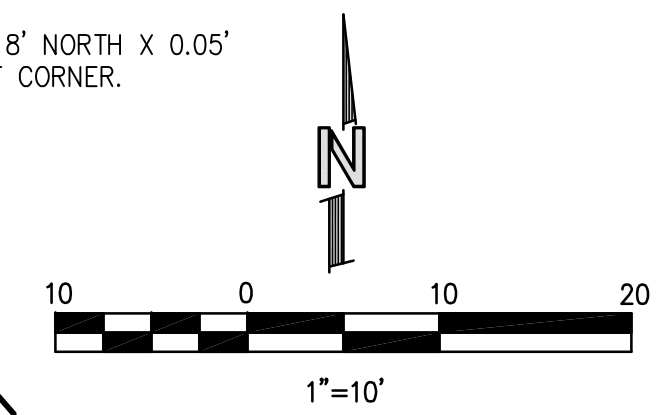

**PATIO DRAIN**

SCALE: NTS **1**

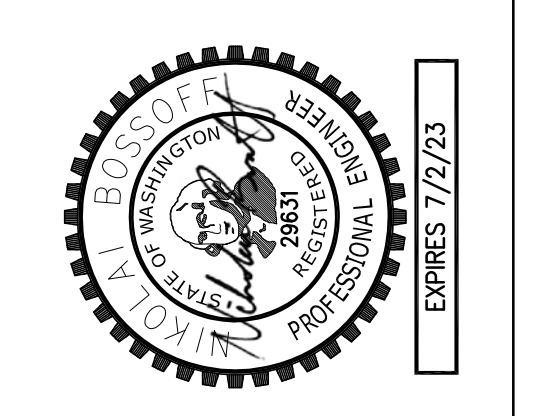
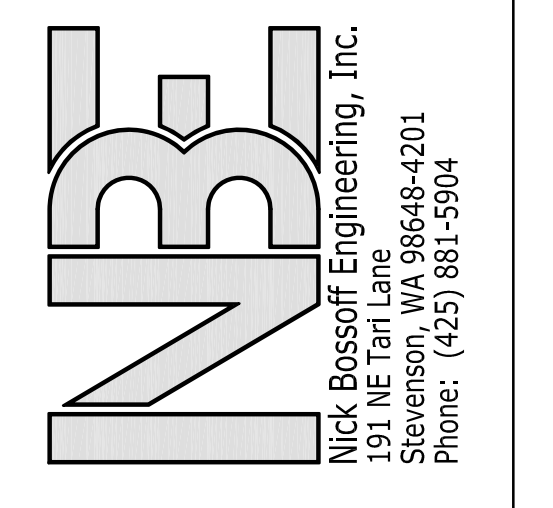

NO.	DATE	REVISION
1	10/18/22	PERMIT SUBMITTAL

N. BOSSOFF, P.E.	PROJECT MANAGER
DESIGNED: NB	DRAWN: TKB
SAARC-2204	JOB NUMBER
SAARC-2204pln.dwg	FILE NAME

**WASHINGTON**

**KNOTZ REMODEL**  
**6020 94TH AVE SE**

---

TITLE: **DRAINAGE PLAN**

---

SHEET: **C-2**

SW1/4, SE1/4, SEC. 19, T. 24 N., R. 5 E., W.M.

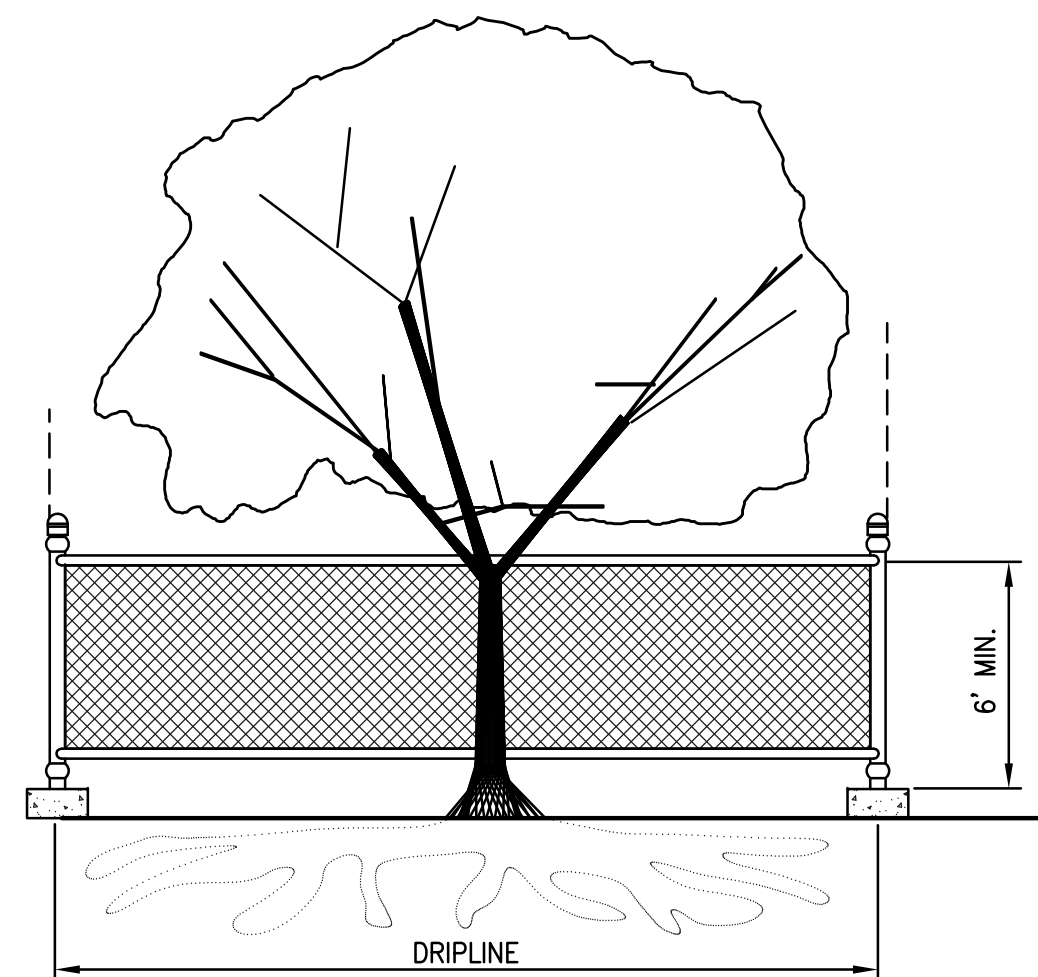

**TREE PROTECTION DURING CONSTRUCTION**

- 6-FT. HIGH TEMPORARY CHAIN LINK FENCE SHALL BE PLACED AT THE DRIPLINE OF THE TREE TO BE SAVED. FENCE SHALL COMPLETELY ENIRCLE THE TREE(S). INSTALL FENCE POSTS USING PIER BLOCKS ONLY. AVOID DRIVING POSTS OR STAKES INTO MAJOR ROOTS.
- FOR ROOTS OVER 1-IN DIA. THAT ARE DAMAGED DURING CONSTRUCTION, MAKE A CLEAN, STRAIGHT CUT TO REMOVE THE DAMAGED PORTION. ALL EXPOSED ROOTS SHALL BE TEMPORARILY COVERED WITH DAMP BURLAP TO PREVENT DRYING, AND SHALL BE COVERED WITH SOIL AS SOON AS POSSIBLE.
- WORK WITHIN PROTECTION FENCE SHALL BE DONE MANUALLY. NO STOCKPILING OF MATERIALS, VEHICULAR TRAFFIC, OR STORAGE OF EQUIPMENT OR MACHINERY SHALL BE ALLOWED WITHIN THE LIMIT OF THE FENCING.

**TREE PROTECTION**

SCALE: NTS

1

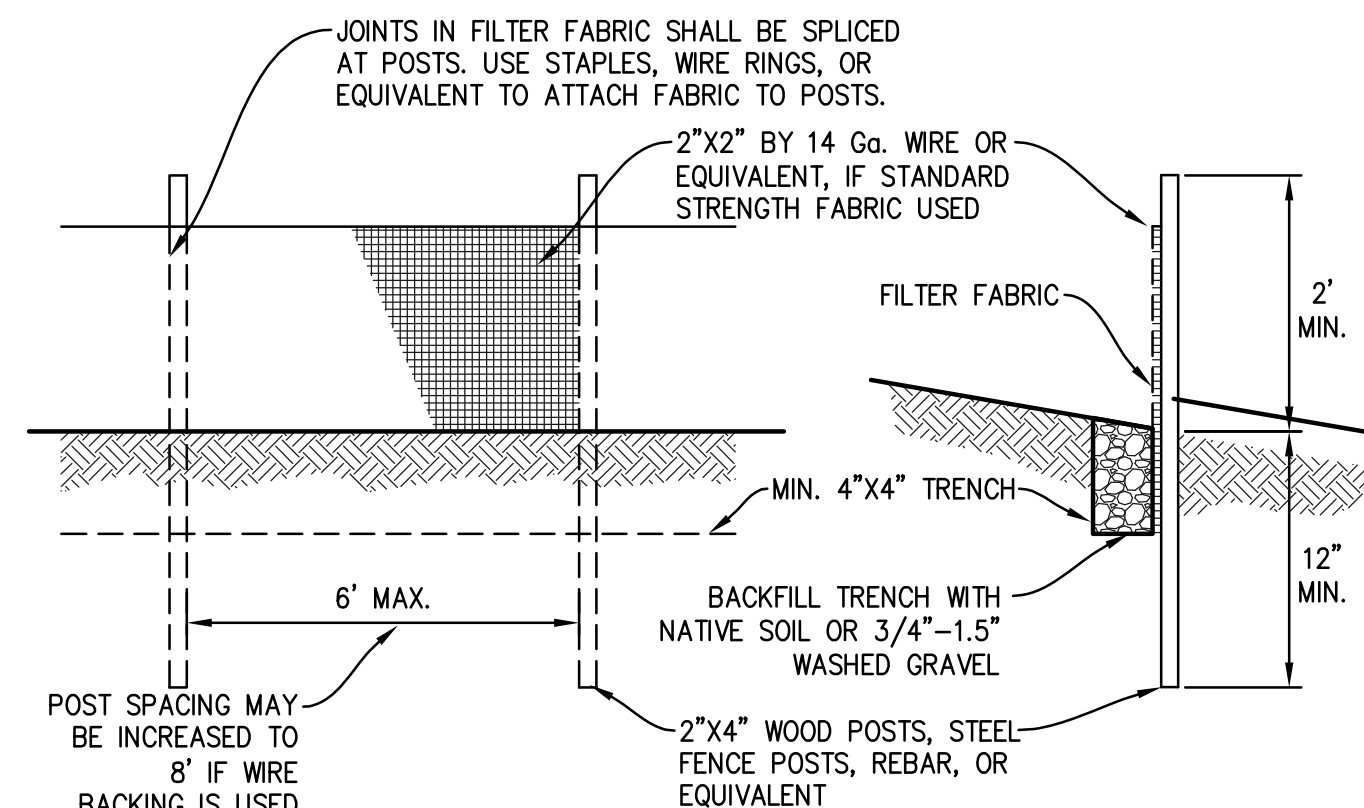

**MAINTENANCE STANDARDS**

- ANY DAMAGE SHALL BE REPAIRED IMMEDIATELY.
- IF CONCENTRATED FLOWS ARE EVIDENT UPHILL OF THE FENCE, THEY MUST BE INTERCEPTED AND CONVEYED TO A SEDIMENT TRAP OR POND.
- IT IS IMPORTANT TO CHECK THE UPHILL SIDE OF THE FENCE FOR SIGN OF THE FENCE CLOGGING AND ACTING AS A BARRIER TO FLOW AND THEN CAUSING CHANNELIZATION OF FLOWS PARALLEL TO THE FENCE. IF THIS OCCUR, REPLACE THE FENCE AND/OR REMOVE THE TRAPPED SEDIMENT.
- SEDIMENT MUST BE REMOVED WHEN THE SEDIMENT IS 6" HIGH.
- IF THE FILTER FABRIC HAS DETERIORATED DUE TO ULTRAVIOLET BREAKDOWN, IT SHALL BE REPLACED.

**SILT FENCE**

SCALE: NTS

2

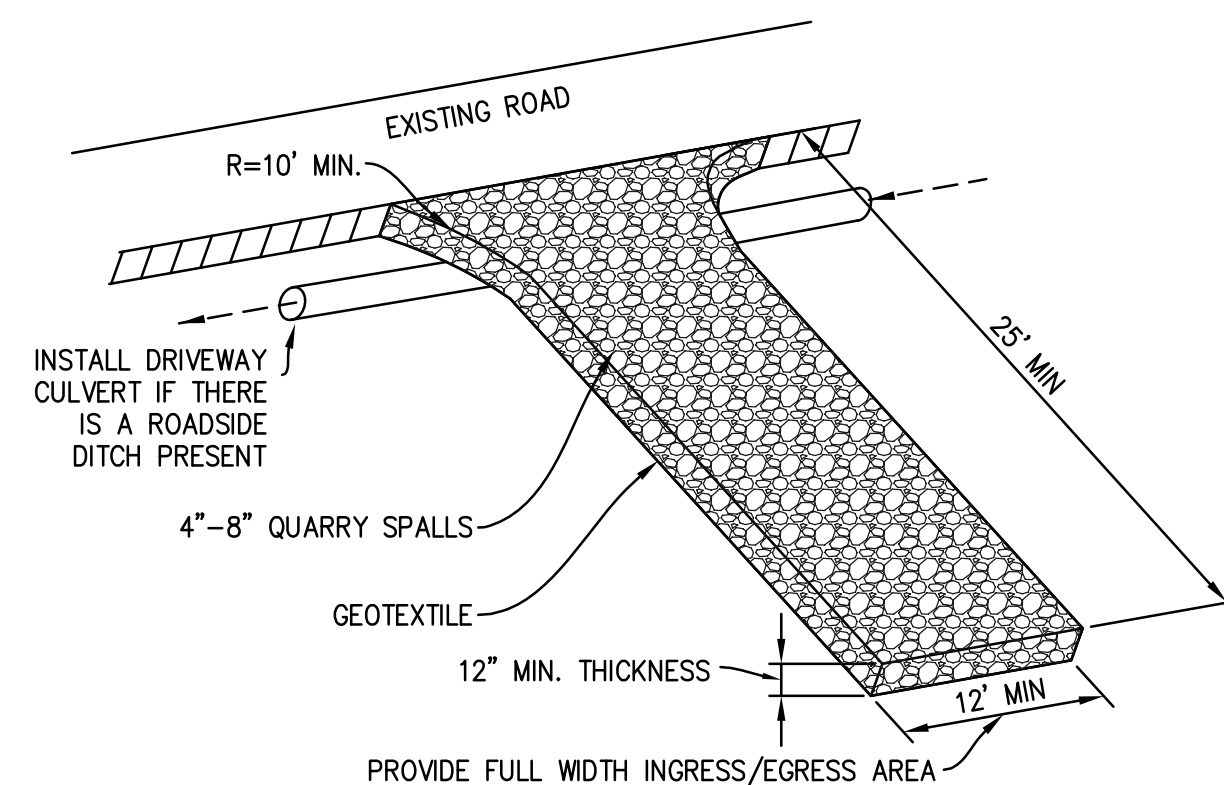

**MAINTENANCE STANDARDS**

- QUARRY SPALLS (OR HOG FUEL) SHALL BE ADDED IF THE PAD IS NO LONGER IN ACCORDANCE WITH THE SPECIFICATIONS.
- IF THE ENTRANCE IS NOT PREVENTING SEDIMENT FROM BEING TRACKED ONTO PAVEMENT, THEN ALTERNATIVE MEASURES TO KEEP THE STREETS FREE OF SEDIMENT SHALL BE USED. THIS MAY INCLUDE STREET SWEEPING, AN INCREASE IN THE DIMENSIONS OF THE ENTRANCE, OR THE INSTALLATION OF A WHEEL WASH. IF WASHING IS USED, IT SHALL BE DONE ON AN AREA COVERED WITH CRUSHED ROCK, AND WASH WATER SHALL DRAIN TO A SEDIMENT TRAP OR POND.
- ANY SEDIMENT THAT IS TRACKED ONTO PAVEMENT SHALL BE REMOVED IMMEDIATELY BY SWEEPING. THE SEDIMENT COLLECTED BY SWEEPING SHALL BE REMOVED OR STABILIZED ON-SITE. THE PAVEMENT SHALL NOT BE CLEANED BY WASHING DOWN THE STREET, EXCEPT WHEN SWEEPING IS INEFFECTIVE AND THERE IS A THREAT TO PUBLIC SAFETY. IF IT IS NECESSARY TO WASH THE STREET, THE CONSTRUCTION OF A SMALL SLUMP SHALL BE CONSIDERED. THE SEDIMENT WOULD THEN BE WASHED INTO THE SLUMP.
- ANY ROCK SPALLS THAT ARE LOOSENEED FROM THE PAD AND END UP ON THE ROADWAY SHALL BE REMOVED IMMEDIATELY.
- IF VEHICLES ARE ENTERING OR EXITING THE SITE AT POINTS OTHER THAN THE CONSTRUCTION ENTRANCE(S), FENCING (SECTION 5.4.1) SHALL BE INSTALLED TO CONTROL TRAFFIC.

**ROCK CONSTRUCTION ENTRANCE**

SCALE: NTS

3

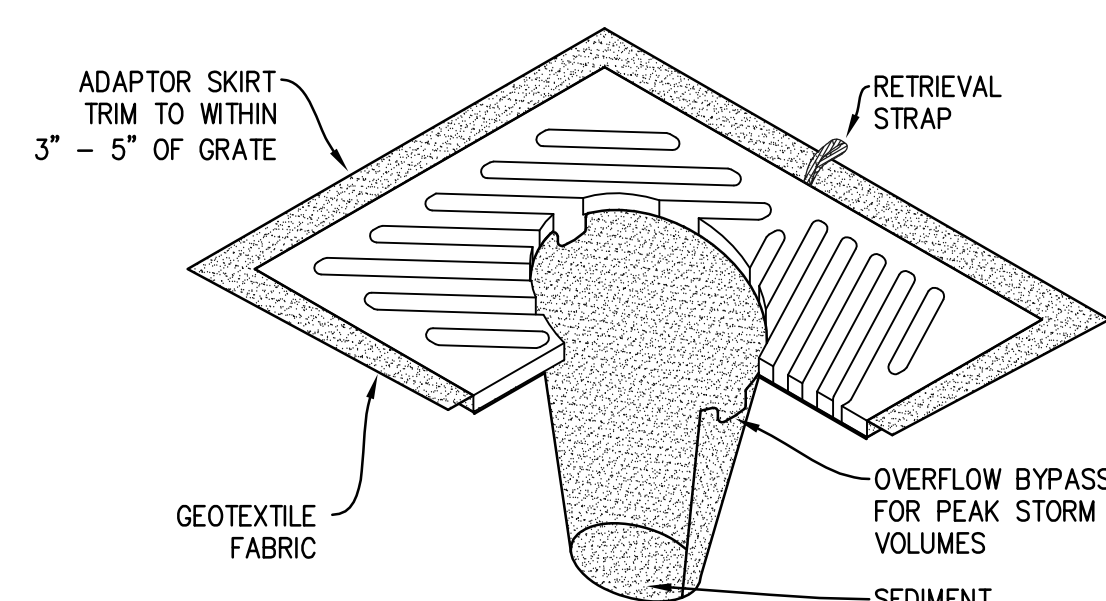

**NOTES**

- INSERT SHALL BE INSTALLED PRIOR TO CLEARING AND GRADING ACTIVITY, OR UPON PLACEMENT OF A NEW CATCH BASIN.
- SEDIMENT SHALL BE REMOVED FROM THE UNIT WHEN IT BECOMES HALF FULL.
- SEDIMENT REMOVAL SHALL BE ACCOMPLISHED BY REMOVING THE INSERT, EMPTYING, AND RE-INSERTING IT INTO THE CATCH BASIN.

**CB INSERT**

SCALE: NTS

4

### ATTACHMENT 1 CITY OF MERCER ISLAND ON-SITE DETENTION SYSTEM WORKSHEET (FOR NEW PLUS REPLACED IMPERVIOUS AREA OF 9,500 SF OR LESS)

**ELBOW RESTRICTOR DETAIL**

**SECTION A-A**  
CONTROL STRUCTURE DETAIL  
NOT TO SCALE

OWNER: KNOTZ	ADDRESS: 6020 94TH AVE SE	PREPARED BY: NICK BOSSOFF ENG
PERMIT #:	MERCER ISLAND	PHONE: (425) 881-5904
NEW PLUS REPLACED IMPERVIOUS SURFACE AREA (SF): 1,451	DETECTION PIPE DIA (INCH): 48"	DETECTION PIPE LENGTH (FT): 23
SOIL TYPE: C	PIPE MATERIAL: ADS N-12	ORIFICE #1 DIA 0.5 INCH, ELEV 226.50
		ORIFICE #2 DIA 1.2 INCH, ELEV 229.80

**ON-SITE DETENTION SYSTEM NOTES:**

- USE A MINIMUM OF A 3/4 IN. DIA. TYPE 2 CATCH BASIN. THE ACTUAL SIZE IS DEPENDENT ON CONNECTING PIPE MATERIAL AND DIAMETER.
- OUTLET PIPE: MIN. 6 INCH.
- METAL PARTS: CORROSION RESISTANT. NON-GALVANIZED PARTS PREFERRED. GALVANIZED PIPE PARTS TO HAVE ASPHALT TREATMENT.
- FRAME AND LADDER OR STEPS OFFSET SO:
  - A. CLEANOUT GATE IS VISIBLE FROM TOP;
  - B. CLIMB-DOWN SPACE IS CLEAR OF RISER AND CLEANOUT GATE;
  - C. FRAME IS CLEAR OF CURB.
- IF METAL OUTLET PIPE CONNECTS TO CEMENT CONCRETE PIPE, OUTLET PIPE TO HAVE SMOOTH O.D. EQUAL TO CONCRETE PIPE I.D. LESS 1/4 IN.
- PROVIDE AT LEAST ONE 3 X 0.090 GAUGE SUPPORT BRACKET ANCHORED TO CONCRETE WALL WITH 5/8 IN. STAINLESS STEEL EXPANSION BOLTS OR EMBEDDED SUPPORTS 2 IN. INTO CATCH BASIN WALL (MAXIMUM 3'-0" VERTICAL SPACING).
- THE SHEAR GATE SHALL BE MADE OF ALUMINUM ALLOY IN ACCORDANCE WITH ASTM B 28M AND ASTM B 275, DESIGNATION Z332A, OR CAST IRON IN ACCORDANCE WITH ASTM A 48, CLASS 30B. THE LEFT HANDLE SHALL BE MADE OF A SIMILAR METAL TO THE GATE (TO PREVENT GALVANIC CORROSION), IT MAY BE OF SOLID ROD OR HOLLOW TUBING WITH ADJUSTABLE HOOK AS REQUIRED. A NEOPRENE RUBBER GASKET IS REQUIRED BETWEEN THE RISER MOUNTING FLANGE AND THE GATE FLANGE. INSTALL THE GATE SO THAT THE LEVEL-LINE MARK IS LEVEL WHEN THE GATE IS CLOSED. THE MATING SURFACES OF THE LID AND THE BODY SHALL BE MACHINED FOR PROPER FIT. ALL SHEAR GATE BOLTS SHALL BE STAINLESS STEEL.
- THE UPPER CATCH BASIN IS REQUIRED IF THE LENGTH OF THE DETENTION PIPE IS GREATER THAN 50 FT.

**ON-SITE DETENTION SYSTEM NOTES:**

- CALL DEVELOPMENT SERVICES (206-275-7625) 24 HOURS IN ADVANCE FOR A DETENTION SYSTEM INSPECTION BEFORE BACKFILLING AND FOR FINAL INSPECTIONS.
- RESPONSIBILITY FOR OPERATION AND MAINTENANCE OF DRAINAGE SYSTEMS ON PRIVATE PROPERTY IS RESPONSIBILITY OF THE PROPERTY OWNER. MATERIAL ACCUMULATED IN THE STORAGE PIPE MUST BE REMOVED FROM CATCH BASINS TO ALLOW PROPER OPERATION. THE OUTLET CONTROL ORIFICE MUST BE KEPT OPEN AT ALL TIMES.
- PIPE MATERIAL, JOINT, AND PROTECTIVE TREATMENT SHALL BE IN ACCORDANCE WITH SECTION 7.04 AND 8.05 OF THE MSDOT STANDARD SPECIFICATION FOR ROAD, BRIDGE, AND MUNICIPAL CONSTRUCTION, LATEST VERSION. SUCH MATERIALS INCLUDE THE FOLLOWING: LINED CORRUGATED POLYETHYLENE PIPE (LOPE), ALUMINUM TYPE 2 CORRUGATED STEEL PIPE AND PIPE ARCH (MEETS ASHTO DESIGNATIONS M274 AND M36), CORRUGATED OR SPIRAL RIB ALUMINUM PIPE, OR REINFORCED CONCRETE PIPE. CORRUGATED STEEL PIPE IS NOT ALLOWED.
- FOOTING DRAINS SHALL NOT BE CONNECTED TO THE DETENTION SYSTEM.

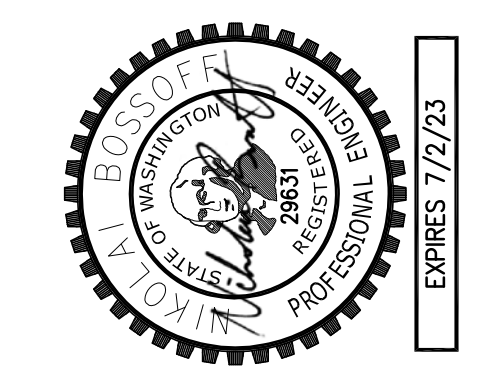
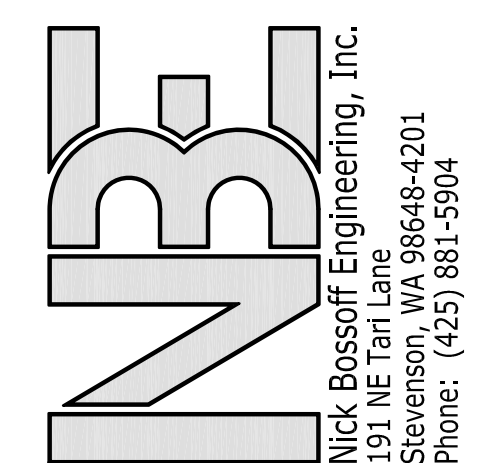

NO.	REVISION	DATE
1	PERMIT SUBMITTAL	10/18/22

PROJECT MANAGER: N. BOSSOFF, P.E.	DESIGNED: NB	DRAWN: TKB
		JOB NUMBER: SARC-2204
		FILE NAME: SARC-2204p1n.dwg

WASHINGTON

MERCER ISLAND

KNOTZ REMODEL  
6020 94TH AVE SE

DETAILS

C-3